

WR Switch under RFC 2889

“Benchmarking Methodology for LAN
Switching Devices”

Cesar Prados and Jiaoni Bai
Timing Group, CS-CO
GSI, August 2016

1. Intro

2. RFC 2889 Test

2.1 1 WR Switch under Test

2.1.1 Full Mesh Result

Forwarding Test Results

Throughput Test Results

2.1.2 Part Mesh 1: N Results

Forwarding Test Result

Throughput Test Results

2.1.3 Part Mesh N: N Results

Forwarding Test Results

Throughput Test Results

2.1.4 Congestion Control

2.1.5 Forward Pressure

2.1.6 Maximum Forwarding Rate

2.1.7 Address Caching Capacity and Learning Rate

2.1.8 Errored Frames Filtering

2.1.9 Broadcast Forwarding

2.2 4 WR Switch under Test

2.2.1 Full Mesh Result

Forwarding Test Results

Throughput Test Results

2.2.2 Part Mesh 1: N Results

Forwarding Test Result

Throughput Test Results

2.2.3 Part Mesh N: N Results

Forwarding Test Results

Throughput Test Results

2.2.4 Congestion Control

2.2.5 Forward Pressure

2.2.5 Maximum Forwarding Rate

2.2.7 Address Caching Capacity and Learning Rate

2.2.8 Errored Frames Filtering

2.2.9 Broadcast Forwarding

3. Result Overview

3.1 Result Summary 1 WR Switch

3.2 Result Summary 4 WR Switch

3.3 Creotech and 7Solutions WR Switches

3.4 Follow-Up Work

1. Intro

The Timing Group of the Common System Control Operation department of GSI has put the WR Switch to the test. We have used the Traffic Generator Xena Bay¹ equipped with three M6SFP² modules (18 ports in total) and the latest WR Switch hardware and firmware³.

We have chosen the “RFC 2889 - Benchmarking Methodology for Lan Switches”, because it is a great methodology to measure the performance of Layer 2 switches and the networks on which they will be deployed. We have run the test in a local network with 1 WR Switch and 4 WR Switches connected in cascade.

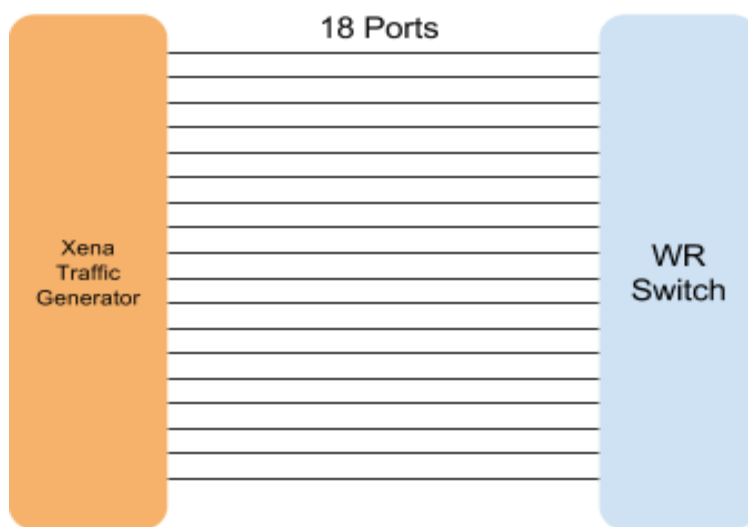

Connection of Xena Traffic Generator and 1 WR Switch

The RFC tests are provided by Xena Software Xena2889⁴. We have only adjusted the time duration of the tests and in some cases, just defined which ports are source and/or destination. For this reason, even if we are not professional network testers, we are quite confident that we haven't made any big mistake in the configuration of the benchmarking. In any case, if you are interested in repeating the tests and validate our results, the configuration for the tests are in our repository⁵.

¹ "Xena Networks Ethernet Testing XenaBay - Xena Networks ..." 2010. 9 Aug. 2016
<http://www.nextgigsystems.com/ethernet_testing/xena_bay.html>

² "M6SFP - Xena Networks." 2014. 9 Aug. 2016
<<http://www.xenanetworks.com/test-modules/l2-3-test-modules/m6sfp/>>

³ WR Hardware PCB:3.30, FPGA:LX240T
WR Firmware: v4.2 (Grzegorz Daniluk); compiled at Aug 28 2015 15:05:21

⁴ "Xena2889 - benchmark performance of Layer 2 LAN ... - Xena Networks." 2014. 9 Aug. 2016
<<http://www.xenanetworks.com/test-software/l2-3-test-suites/xena2889/>>

⁵ https://github.com/GSI-CS-CO/network_testing.git

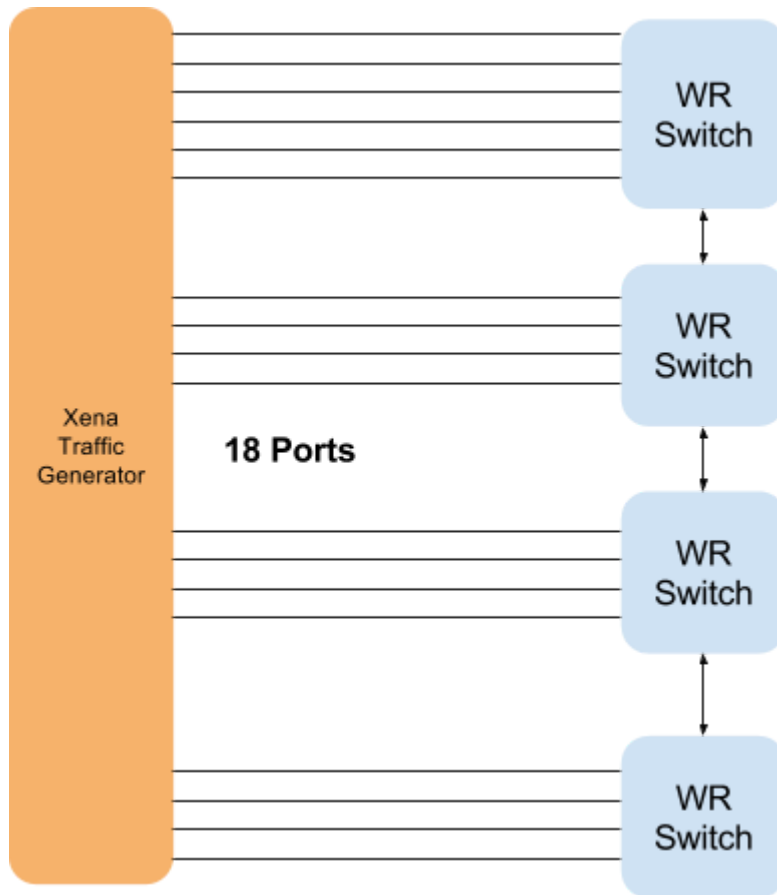

Connection of Xena Traffic Generator and 4 WR Switch

2. RFC 2889 Test

This RFC primarily deals with devices which switch frames at the Medium Access Control (MAC) layer. It provides a methodology for benchmarking switching devices, forwarding performance, congestion control, latency, address handling and filtering. For more information about these Tests, please check the RFC 2889⁶ document or the more readable doc from Spirent⁷. Below we present a short description of every tests and goals. You may use it as a cheat sheet while you are checking the results of the test.

The **Full Mesh test** determines the throughput, frame loss and forwarding rates of the switch in a full mesh of traffic, from all-ports to all-ports. Fully meshed traffic stresses the switch fabric, fully exercises the forwarding tables and reveals weaknesses in resource allocation mechanisms.

The **Part Mesh 1:N** test determines the throughput, frame loss and forwarding rates of the switch when the stream is transmitted from one-to-N ports or from N-to-one port, measuring the capability of the device to switch frames without losses and determining the ability to utilize a port when switching traffic from multiple ports.

The **Part Mesh N:N** test determines the throughput, frame losses and forwarding rates of the switch when multiple streams of one-way traffic using half of the ports on the switch are sending frames to the other half of the ports.

All these test are splitted into:

- *Forwarding Test*: Forwarding rate of the switch is reported as the number of test frames per second that the device is observed to successfully forward to the correct destination interface⁸.
- *Throughput Test*: The maximum rate at which none of the offered frame are dropped by the device.

The **Congestion Control** test determines how a switch handles congestion, whether the device implements congestion control and whether congestion on one port affects an uncongested port.

⁶ Mandeville, R. "Information on RFC 2889 » RFC Editor." 2000. <<https://www.rfc-editor.org/info/rfc2889>>

⁷ "Layer 2 Testing with RFC 2889 - Newegg.com." 2015. 9 Aug. 2016

<http://images10.newegg.com/UploadFilesForNewegg/itemintelligence/WAGAN/Layer_202_20Testing_20with_20RFC_2028891445071217740.pdf>

⁸ If you check the original report, the PASS criteria is just anecdotic and it is not meaningful. Xena provides PASS state for all tests for the sake of symmetry.

The **Forward Pressure** test overloads a switch port and measures the output for forward pressure. If the switch transmits frames with an interpacket gap⁹ less than 96 bits, then forward pressure should be detected.

The **Maximum Forwarding Rate** test measures the peak value of the forwarding rate when the load is varied between the throughput value derived from the previous tests and the maximum load.

The **Address Caching Capacity** test measures the number of the MAC addresses that a switch can cache within the a specified time and successfully forward without flooding or dropping frames. The **Address Learning Rate** determines the rate of address learning of a LAN switching device.

The **Errored Frames Filtering** test determines the behavior of the switch under error or abnormal frame conditions. The results of the test indicate whether the switch filters or forwards errored frames.

The **Broadcast Frame Forwarding and Latency** test determines the throughput and latency of the switch when forwarding broadcast traffic.

The **Frame Loss Rate** is the ratio between lost frames and the number of the theoretic received frames of a tested port.

Jitter is the absolute value of the difference between the latency of two consecutive received frames belonging to the same stream from one Xena port to another Xena port

Latency is the time interval between the time of Xena port receiving a frame and the time of another Xena port sending a frame.

Parameters and setting used in all the test:

- **Packet Sizes Used:** 64,128,256,512,1024,1280,1518
- **Fraction per Port:** 0 - 100,00%
- **Latency Measurement Mode:** Last-To-Last
- **Toggle Port Sync States:** Yes
- **Number of Ports:** 18

⁹ Interpacket gap
https://en.wikipedia.org/wiki/Ethernet_frame#Interpacket_gap

2.1 1 WR Switch under Test

2.1.1 Full Mesh Result

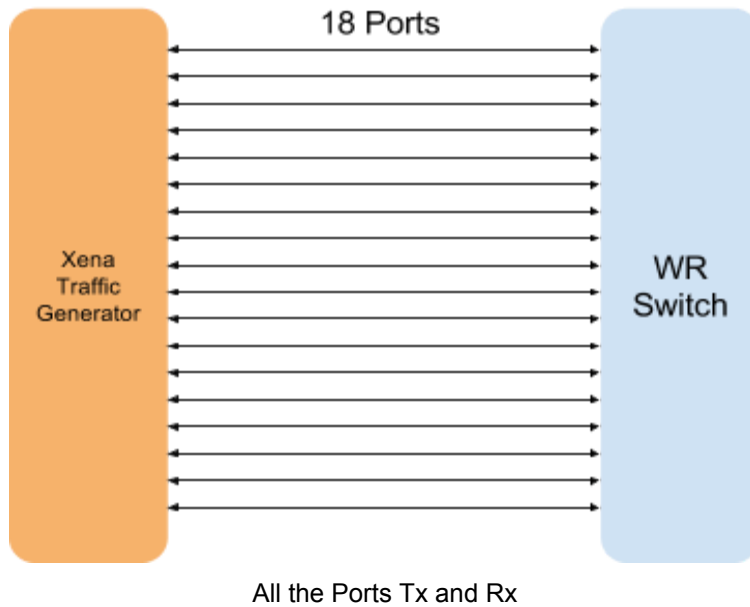

Forwarding Test Results

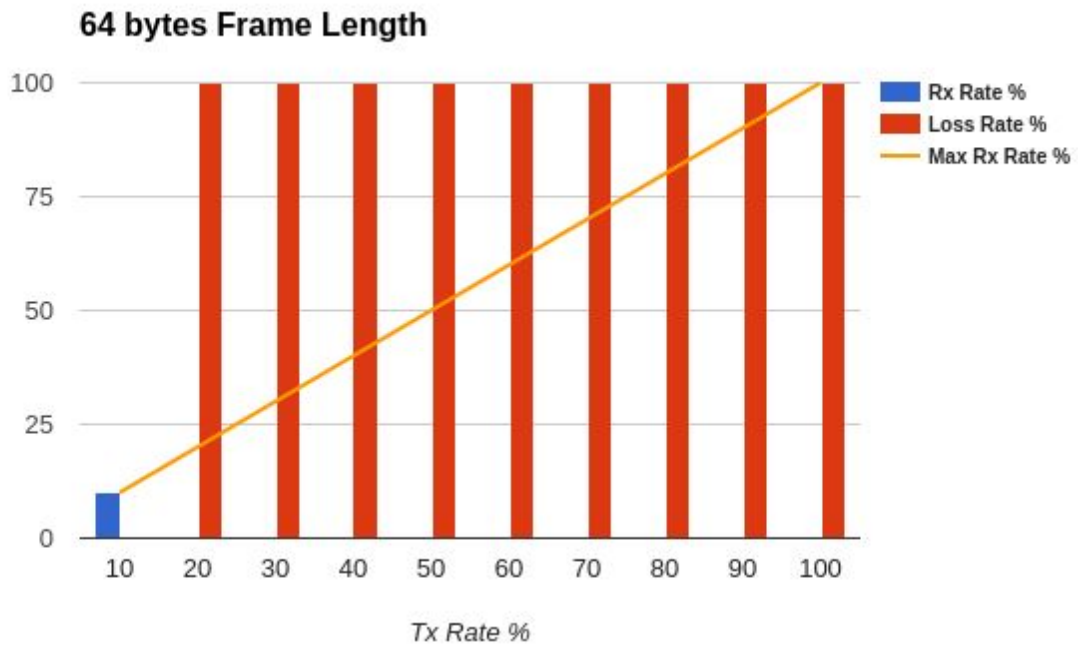

512 bytes Frame Length

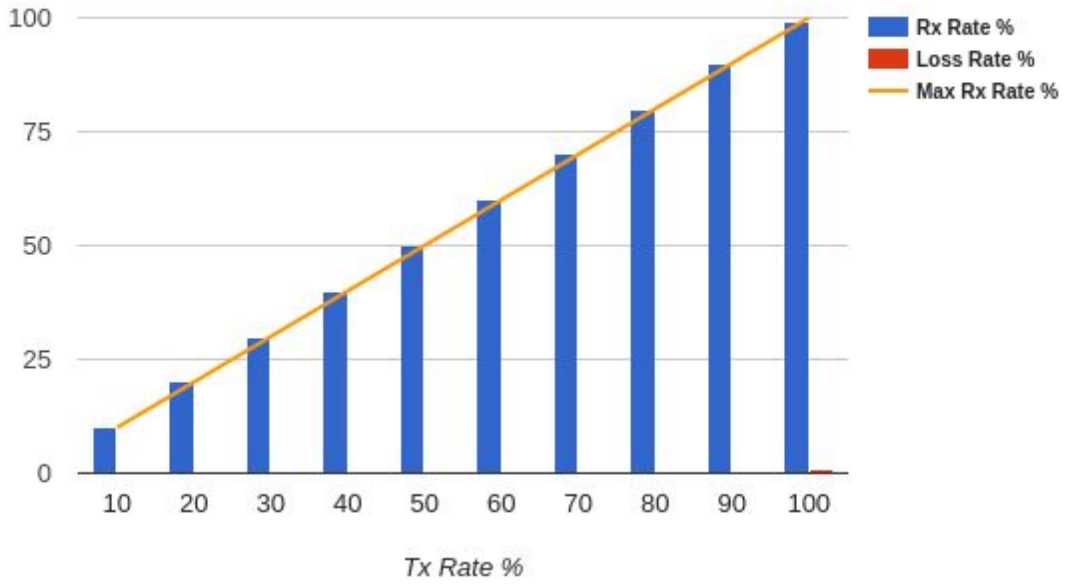

1518 bytes Frame Length

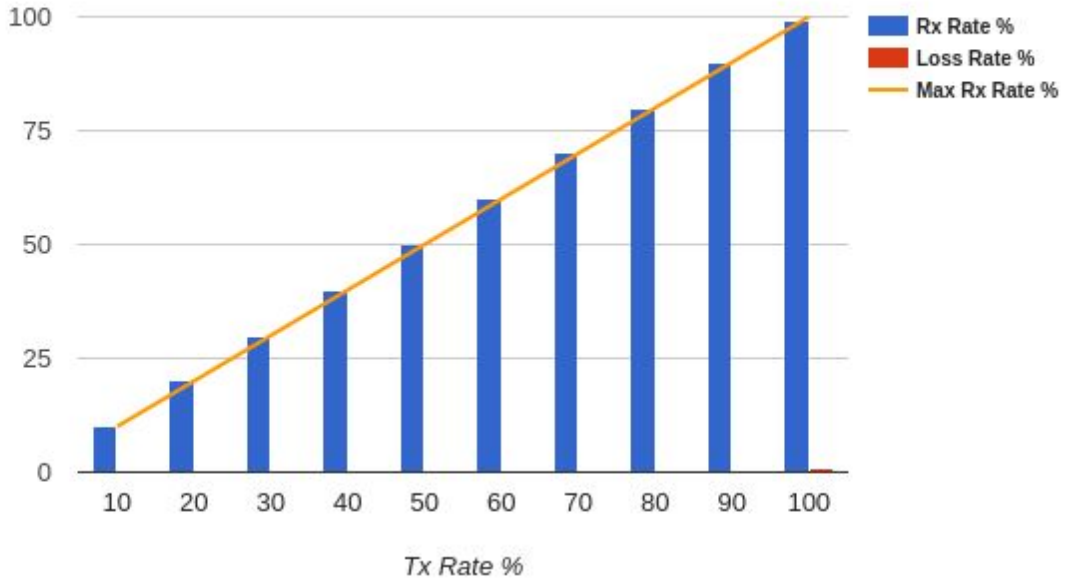

Throughput Test Results

Frame Size	Result State	Max Tx Rate % Achieved	Rx Rate %	Loss Rate %
64	FAIL	10	9,9	0,1
128	FAIL	10	9,9	0,1
256	PASS	52,93	52,93	0
512	PASS	95,17	95,17	0
1024	PASS	39,62	39,62	0
1280	PASS	32,68	32,68	0
1518	PASS	28,63	28,63	0

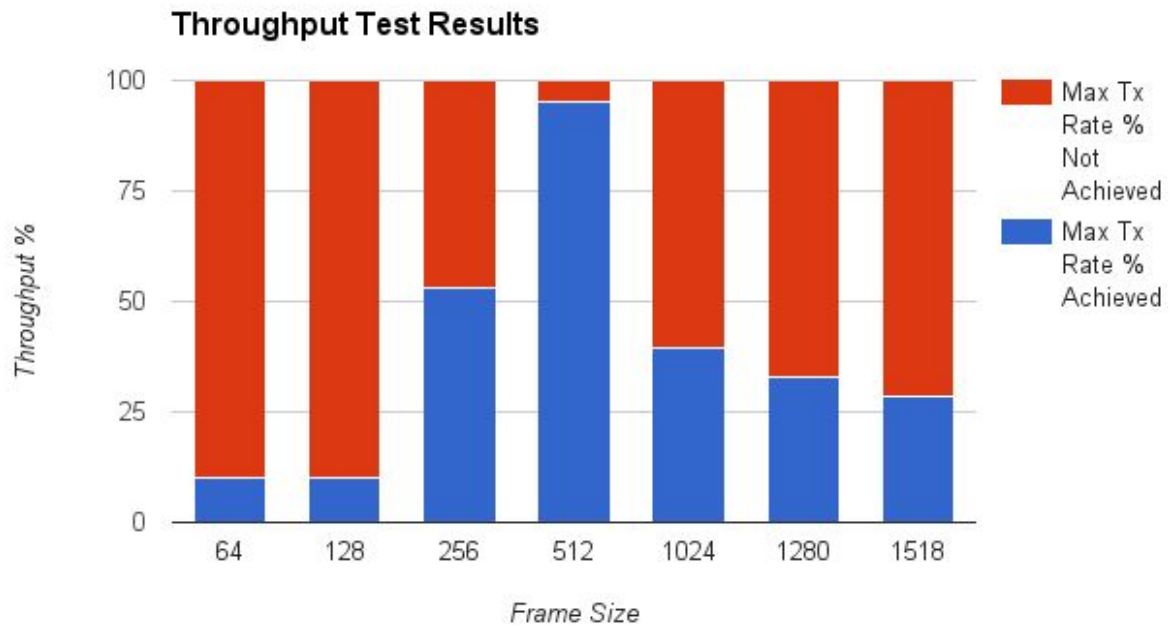

2.1.2 Part Mesh 1: N Results

Forwarding Test Result

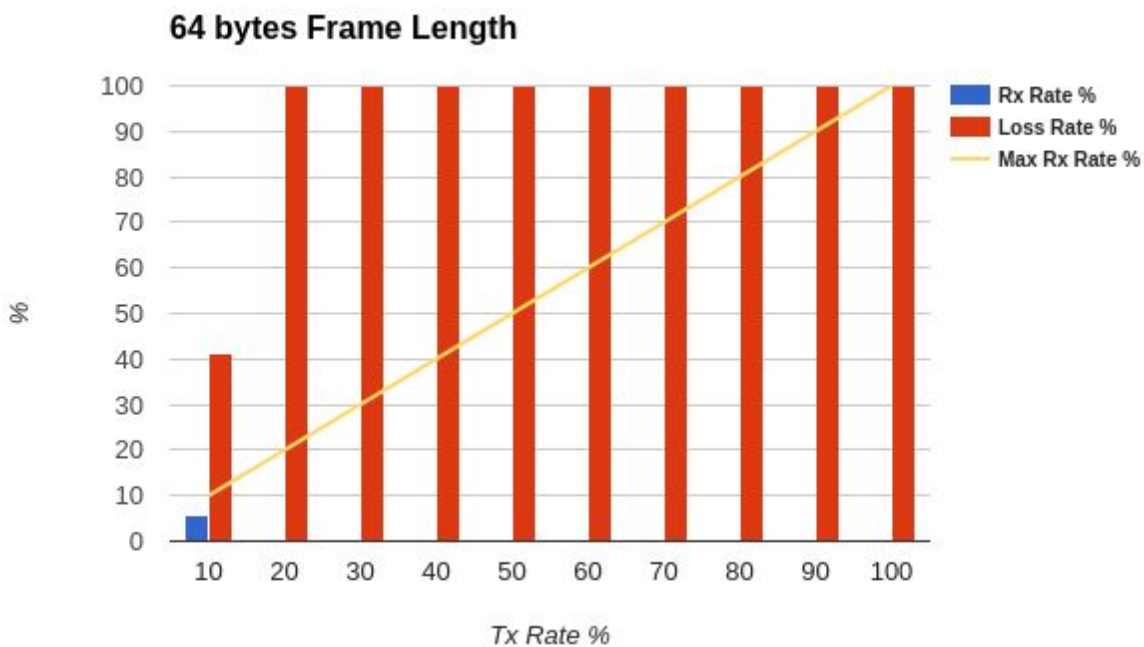
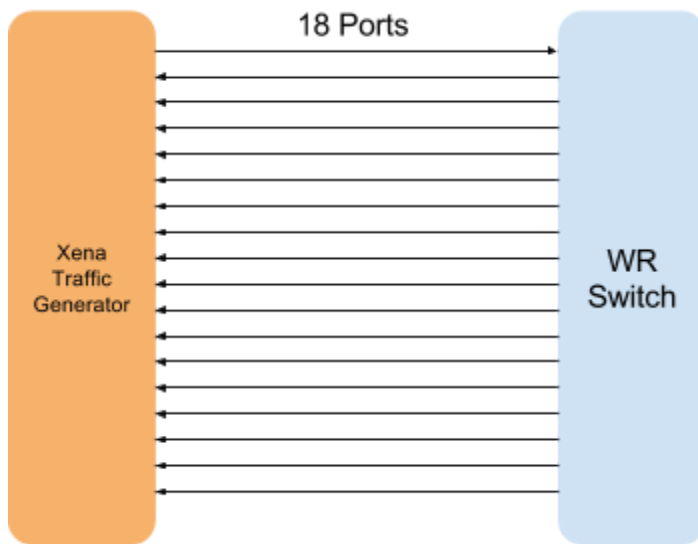

512 bytes Frame Length

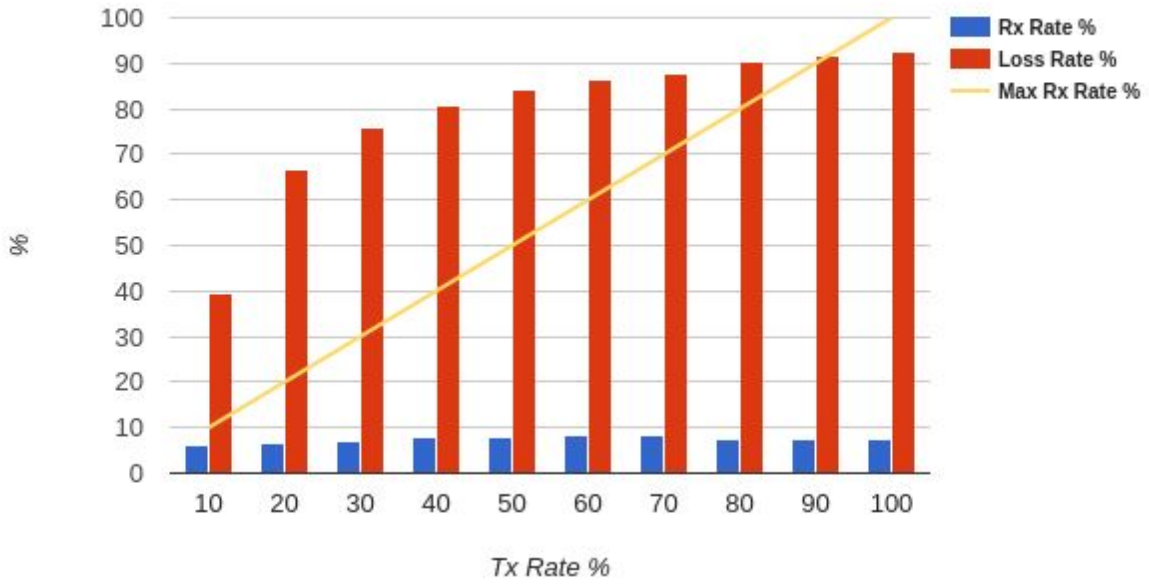

1518 bytes Frame Length

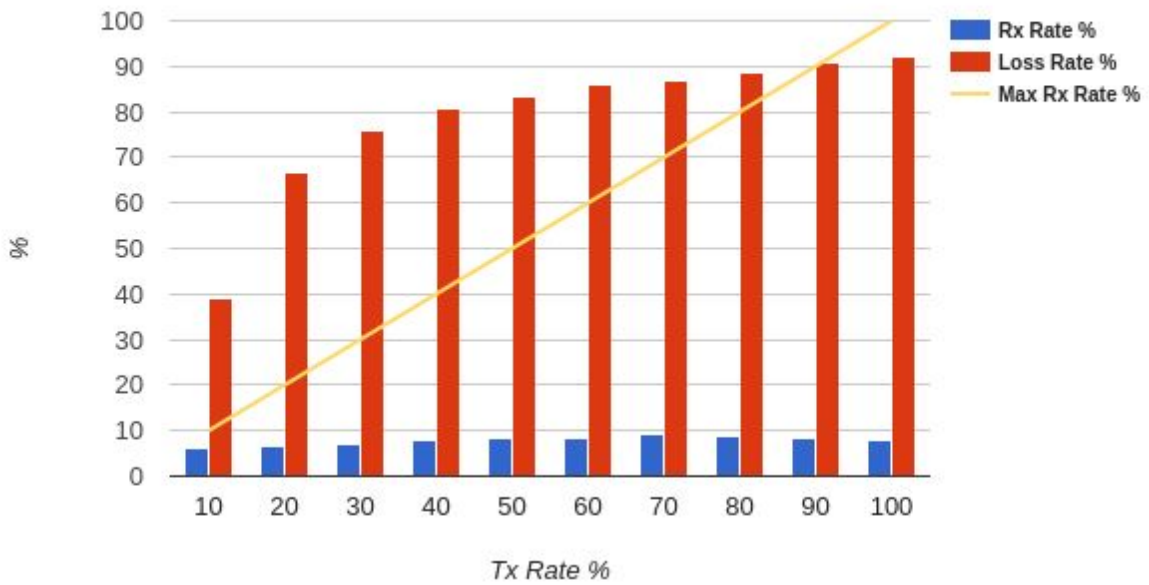

Throughput Test Results

Frame Size	Result State	Max Tx Rate % Achieved	Rx Rate %	Loss Rate %
64	FAIL	10	5,87	41,34
128	FAIL	10	5,97	40,31
256	FAIL	10	6,04	39,64
512	FAIL	10	6,07	39,26
1024	FAIL	10	6,09	39,06
1280	FAIL	10	6,10	39,02
1518	FAIL	10	6,10	38,99

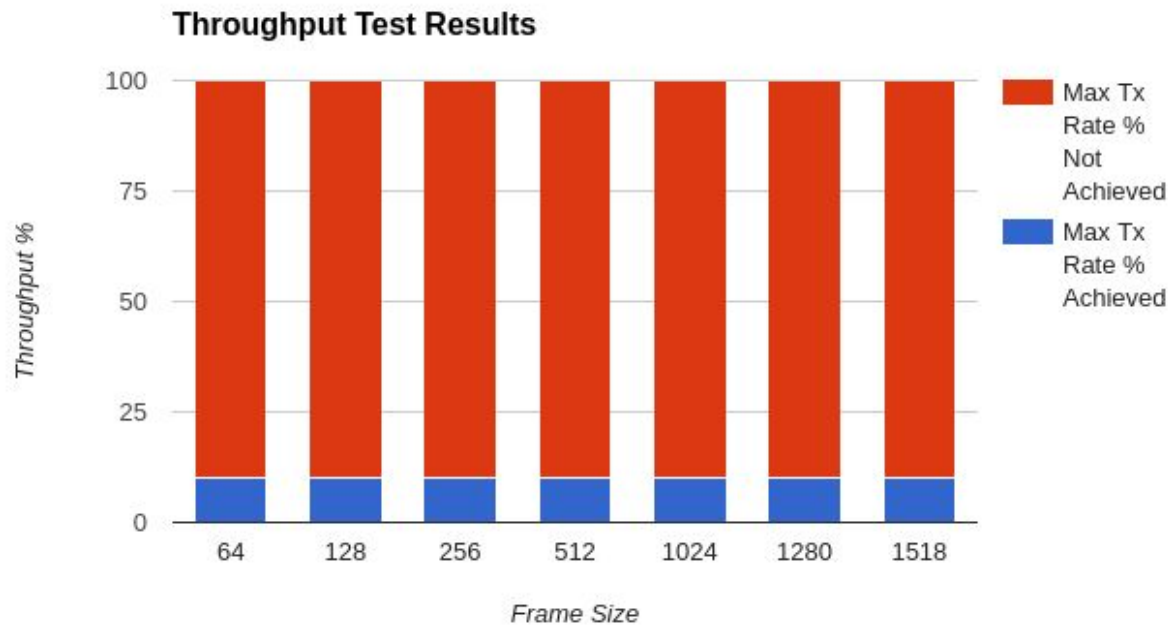

2.1.3 Part Mesh N: N Results

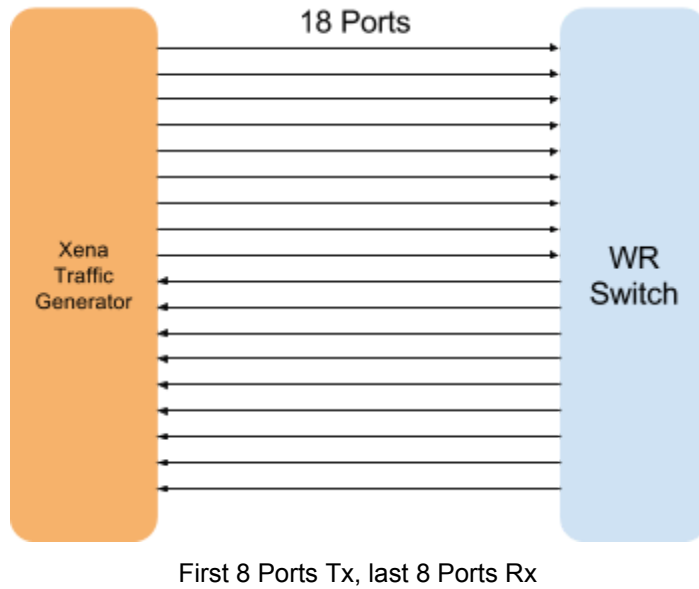

Forwarding Test Results

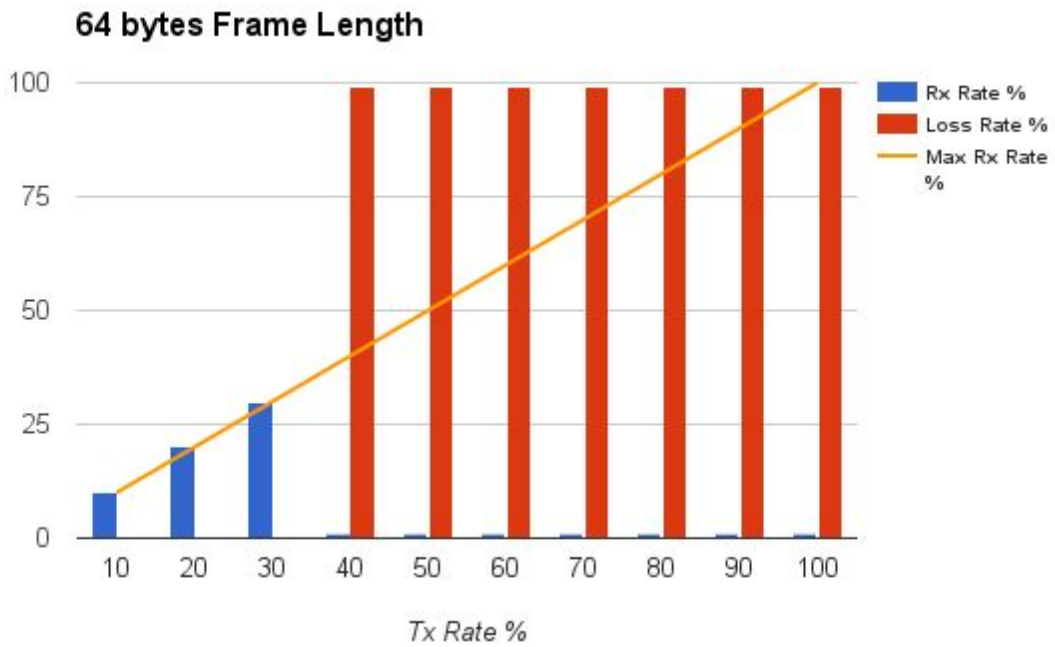

512 bytes Frame Length

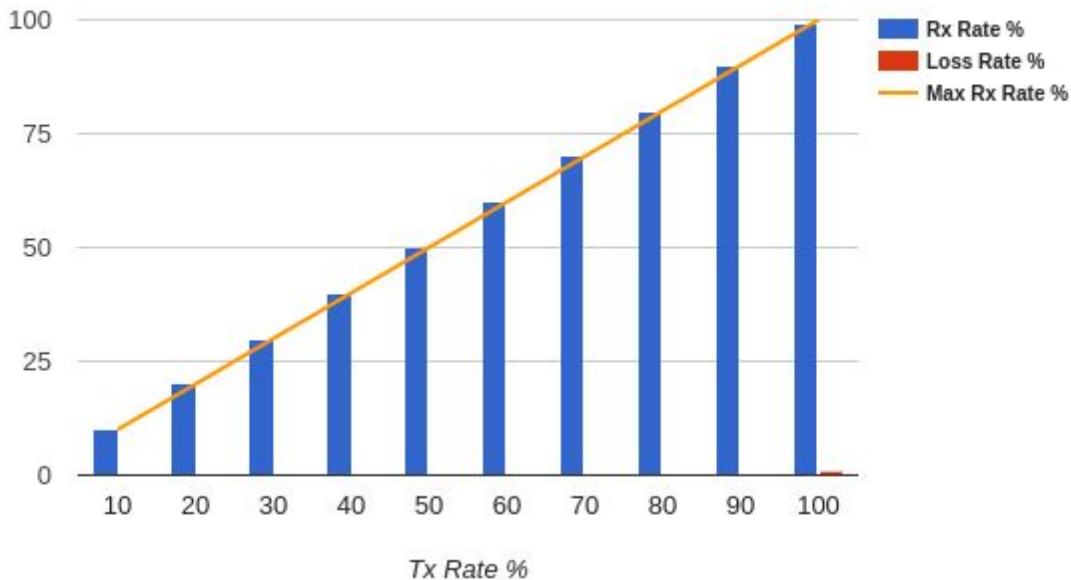

1518 bytes Frame Length

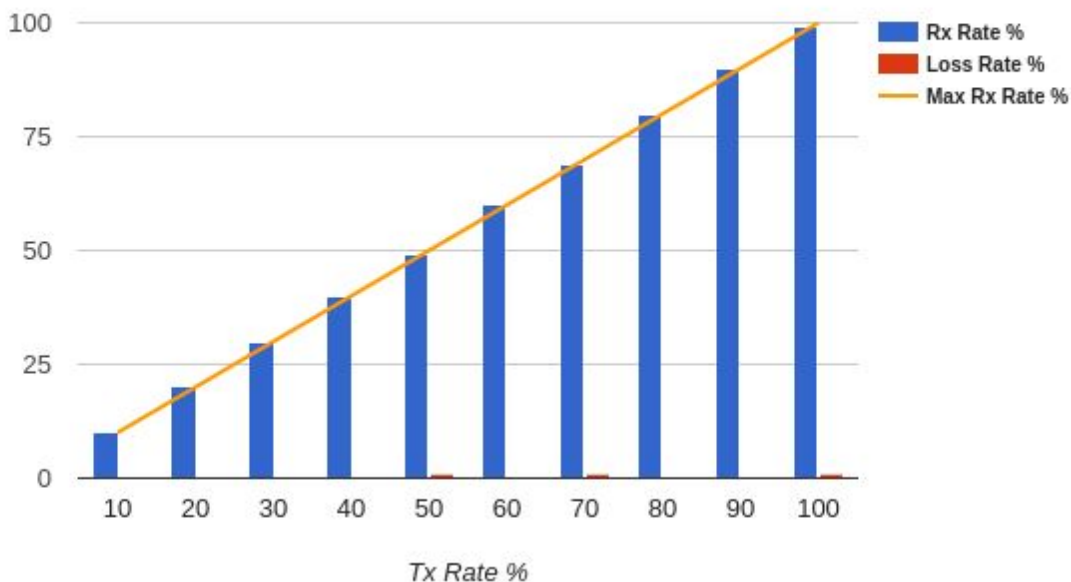

Throughput Test Results

Frame Size	Result State	Max Tx Rate % Achieved	Rx Rate %	Loss Rate %
64	FAIL	10	9,99	0,01
128	PASS	46,56	46,56	0
256	PASS	94,38	94,38	0
512	PASS	94,38	94,38	0
1024	PASS	94,38	94,38	0
1280	PASS	69,06	69,06	0
1518	PASS	94,38	94,38	0

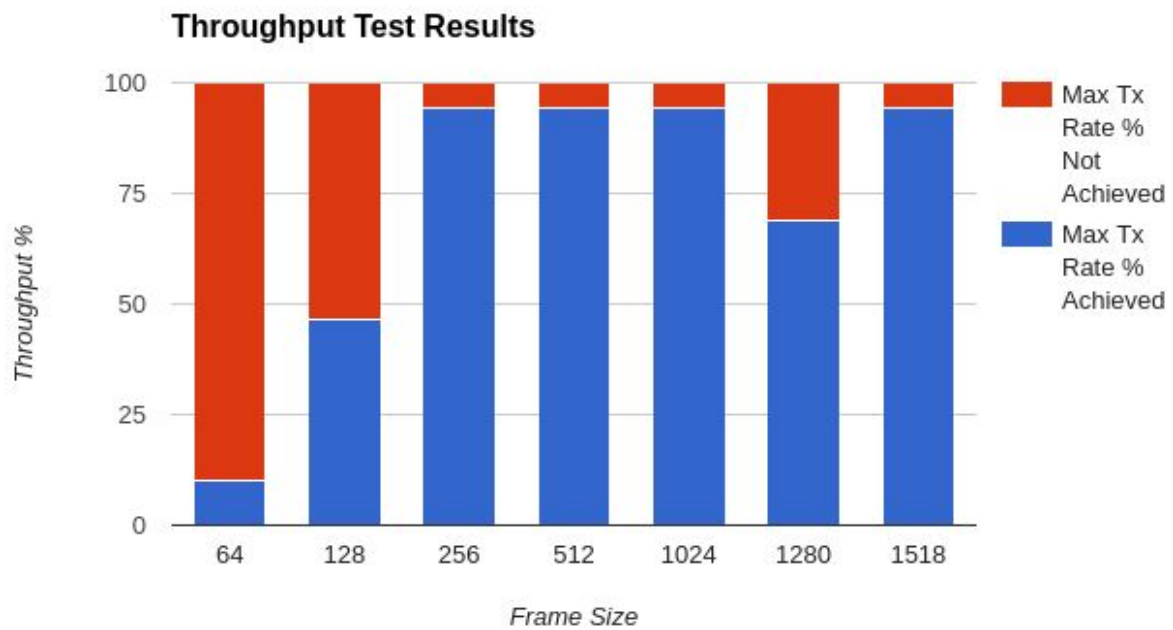

2.1.4 Congestion Control

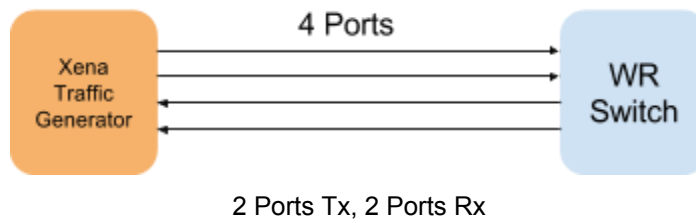

Frame Size	Tx Rate %	Tx	UC-Port: Tx	UC-Port: Rx	UC-Port: Loss %	C-Port: Tx	C-Port: Rx	C-Port: Loss %
64	100	89357331	22337769	22337769	0	67019562	42660356	36,35
128	100	50716615	12678194	12678194	0	38038421	24694862	35,08
256	100	27185677	6795900	6795900	0	20389777	13400918	34,28
512	100	14109200	3527065	3527065	0,58	10582135	7003095	33,82
1024	100	7185964	1796354	1796354	2,16	5389610	3579891	33,58
1280	100	5771001	1442655	1442655	2,83	4328346	2877125	33,53
1518	100	4878685	1219592	1219592	2,53	3659093	2433426	33,50

C-Port: Congested Ports

UC-Port: Uncongested Ports

2.1.5 Forward Pressure

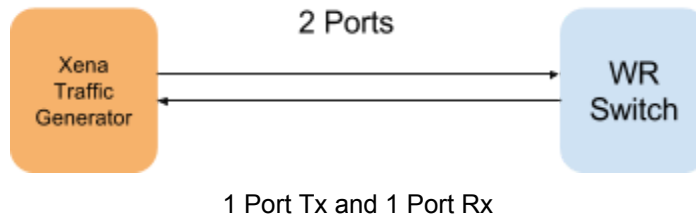

Frame Size	Tx (Frames)	Tx Max. Util. %	Rx (Frames)	Rx Max. Util. %	Loss %
64	45180722	101,2048173	42613533	95,454168	5,68
128	25510204	100,6802718	24671022	97,36805829	3,29
256	13636363	100,3636317	13392864	98,57104217	1,79
512	7062146	100,1883113	6996301	99,2533248	0,93
1024	3595397	100,0958525	3578291	99,61797291	0,48
1280	2886836	100,0769813	2875817	99,69284	0,38
1518	2439817	100,0650279	2431958	99,74013491	0,32

2.1.6 Maximum Forwarding Rate

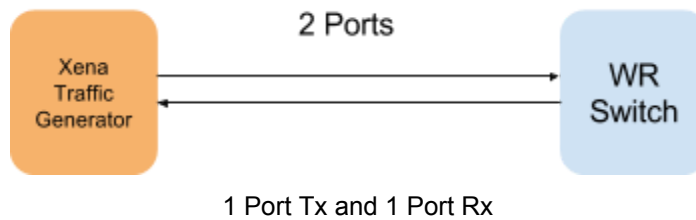

Frame Size	Tx Rate %	Tx (Frames)	Rx (Frames)	Loss %
64	100	44642857	42613548	4,545652175
128	100	25337837	24671016	2,6317203
256	100	13586956	13392866	1,428502455
512	100	7048872	6996303	0,7457788991
1024	100	3591954	3578292	0,3803500824
1280	100	2884615	2875817	0,304997374
1518	100	2438231	2431958	0,2572766895

2.1.7 Address Caching Capacity and Learning Rate

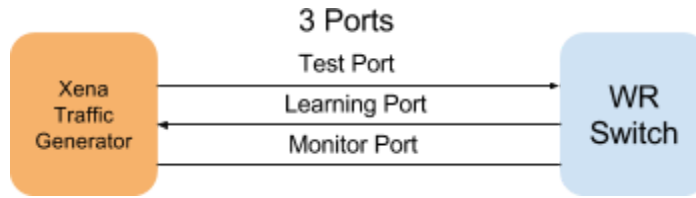

Frame Size	Address Count	TestPort Tx (Frames)	LearnPort Rx (Frames)	Learning Rate %	Address Count	TestPort Tx (Frames)	LearnPort Rx (Frames)
64	1504	1504	1504	94,375	1504	1504	1504
128	1504	1504	1504	94,375	1504	1504	1504
256	1504	1504	1504	94,375	1504	1504	1504
512	1504	1504	1504	94,375	1504	1504	1504
1024	1504	1504	1504	94,375	1504	1504	1504
1280	1504	1504	1504	94,375	1504	1504	1504
1518	1504	1504	1504	94,375	1504	1504	1504

2.1.8 Errored Frames Filtering

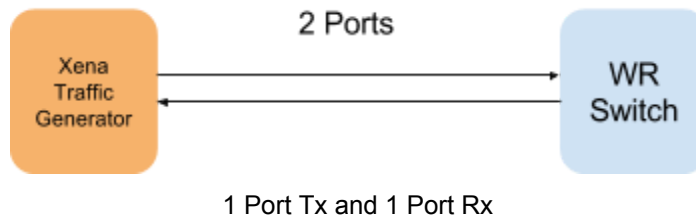

Tx Rate %	Result State	Tx	Rx	Tx Valid	Rx Valid	Tx Oversize	Rx Oversize	Tx Undersize	Rx Undersize
10	FAIL	1741375	1741375	154130	154130	81221	81221	1506024	1506024
20	FAIL	3482752	3482752	308261	308261	162443	162443	3012048	3012048
30	FAIL	5224128	5224128	462392	462392	243664	243664	4518072	4518072
40	FAIL	6965498	6965498	616522	616522	324880	324880	6024096	6024096
50	FAIL	8706880	8706880	770653	770653	406107	406107	7530120	7530120
60	FAIL	10448257	10448257	924784	924784	487329	487329	9036144	9036144
70	FAIL	12189633	12189633	1078914	1078914	568551	568551	10542168	10542168
80	FAIL	13931009	13930542	1233045	1233045	649772	649772	12048192	12047725
90	FAIL	15672386	15671881	1387176	1387176	730994	730994	13554216	13553711
100	FAIL	17413762	13697399	1541307	1476555	812215	636940	15060240	11583904

Tx Rate %	Result State	Tx	Rx	Tx Valid	Rx Valid	Tx FCS Error	Rx FCS Error
10	PASS	1741375	1741375	154130	154130	59	0
20	PASS	3482752	3482752	308261	308261	59	0
30	PASS	5224128	5224128	462392	462392	59	0
40	PASS	6965498	6965498	616522	616522	59	0
50	PASS	8706880	8706880	770653	770653	59	0
60	PASS	10448257	10448257	924784	924784	59	0
70	PASS	12189633	12189633	1078914	1078914	59	0
80	PASS	13931009	13930542	1233045	1233045	59	0
90	PASS	15672386	15671881	1387176	1387176	59	0
100	PASS	17413762	13697399	1541307	1476555	59	0

2.1.9 Broadcast Forwarding

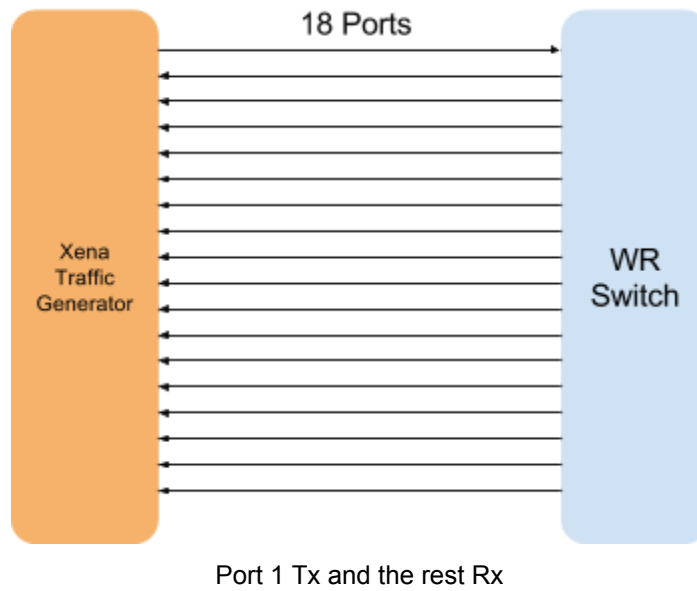

Frame Size	Tx Rate %	Loss Rate %	Loss (Frames)
64	60,625	0	0
128	71,875	0	0
256	80,3125	0	0
512	89,453125	0	0
1024	94,375	0	0
1280	94,375	0	0
1518	94,375	0	0

Frame Size	Latency (avg/min/max) (microsecs)	Jitter (avg/min/max) (microsecs)
64	2,383 / 2,214 / 4,451	0,033 / 0,000 / 2,092
128	2,832 / 2,655 / 4,363	0,019 / 0,000 / 1,587
256	2,844 / 2,671 / 4,547	0,010 / 0,000 / 1,804
512	2,865 / 2,655 / 4,531	0,009 / 0,000 / 1,852
1024	2,869 / 2,671 / 4,355	0,004 / 0,000 / 1,611
1280	2,889 / 2,655 / 4,604	0,003 / 0,000 / 1,563
1518	2,868 / 2,687 / 4,082	0,004 / 0,000 / 1,347

2.2 4 WR Switch under Test

2.2.1 Full Mesh Result

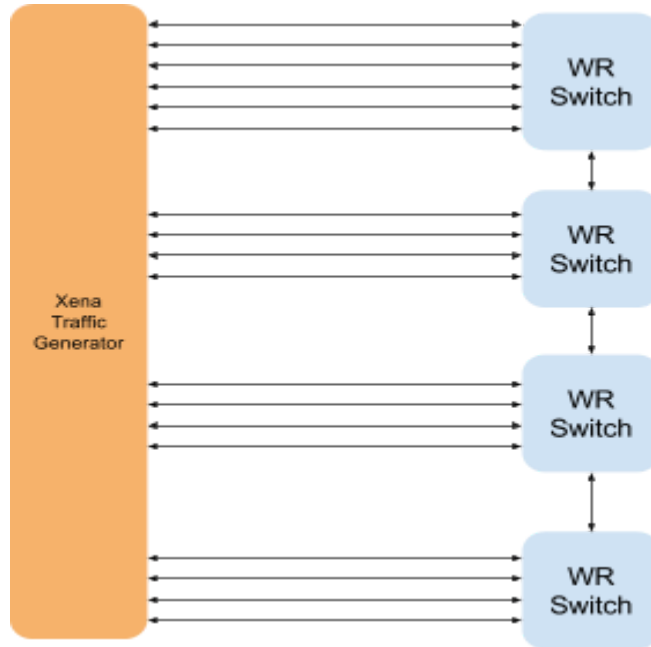

All the Ports Tx and Rx

Forwarding Test Results

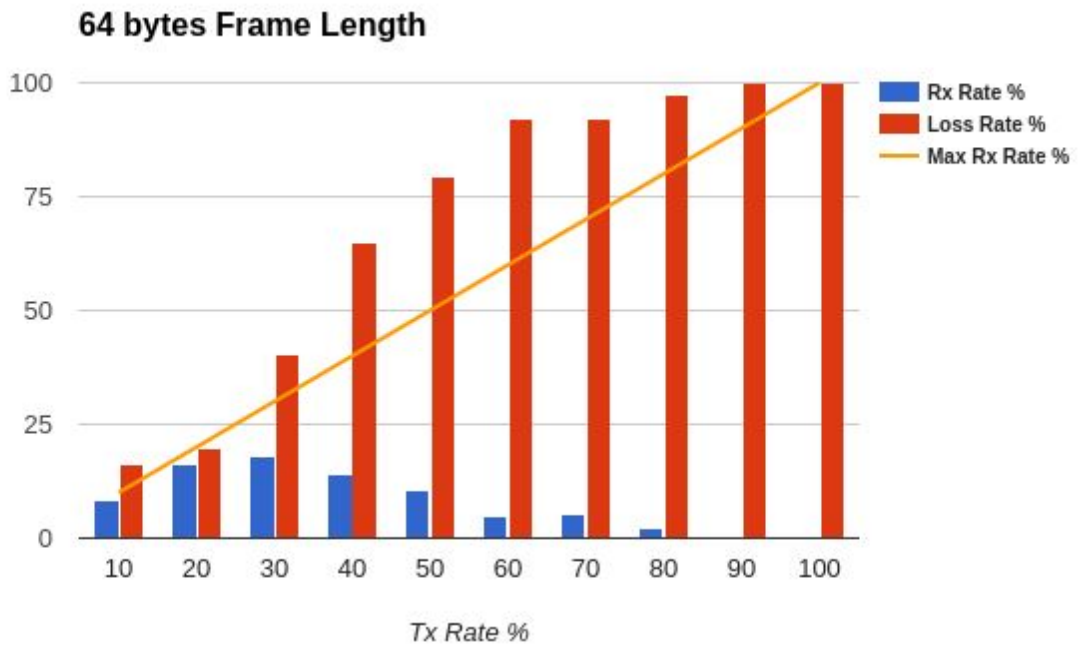

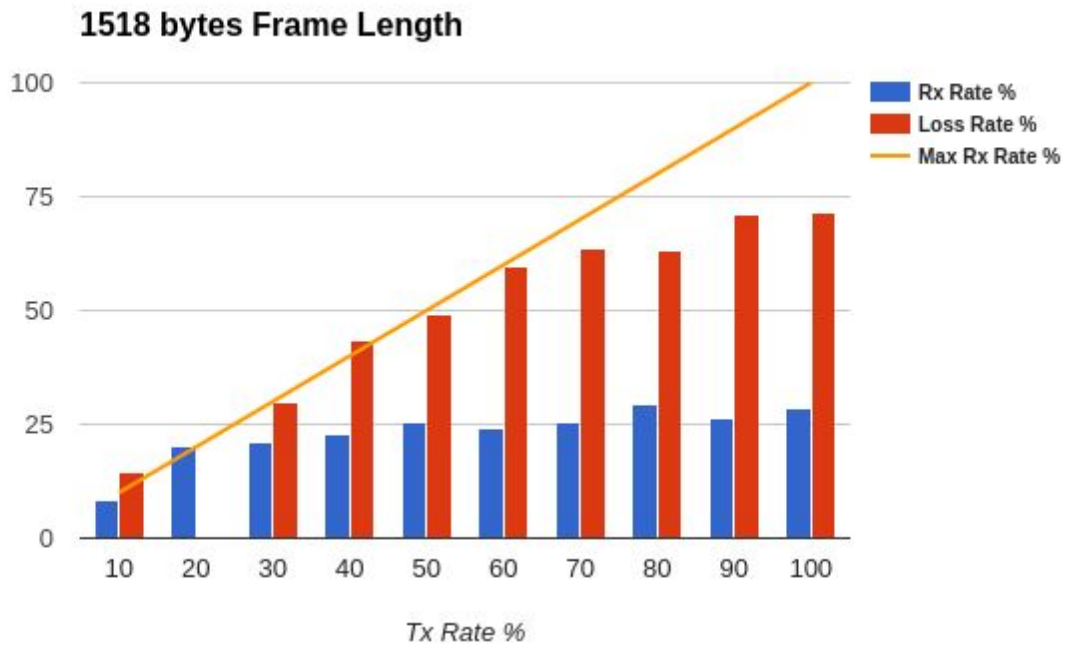
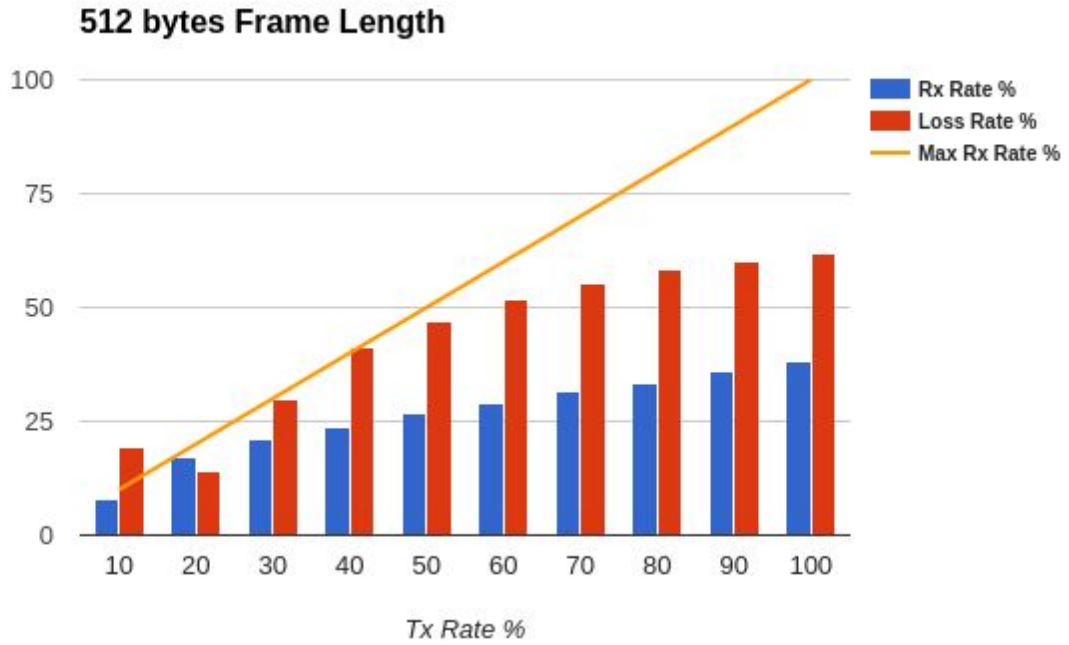

Throughput Test Results

Frame Size	Result State	Max Tx Rate % Achieved	Rx Rate %	Loss Rate %
64	FAIL	10,00	9,99	0,06
128	PASS	20,63	20,63	0,00
256	PASS	20,90	20,90	0,00
512	PASS	20,90	20,90	0,00
1024	FAIL	10,35	8,55	17,38
1280	FAIL	10,00	8,11	18,91
1518	FAIL	10,00	7,85	21,52

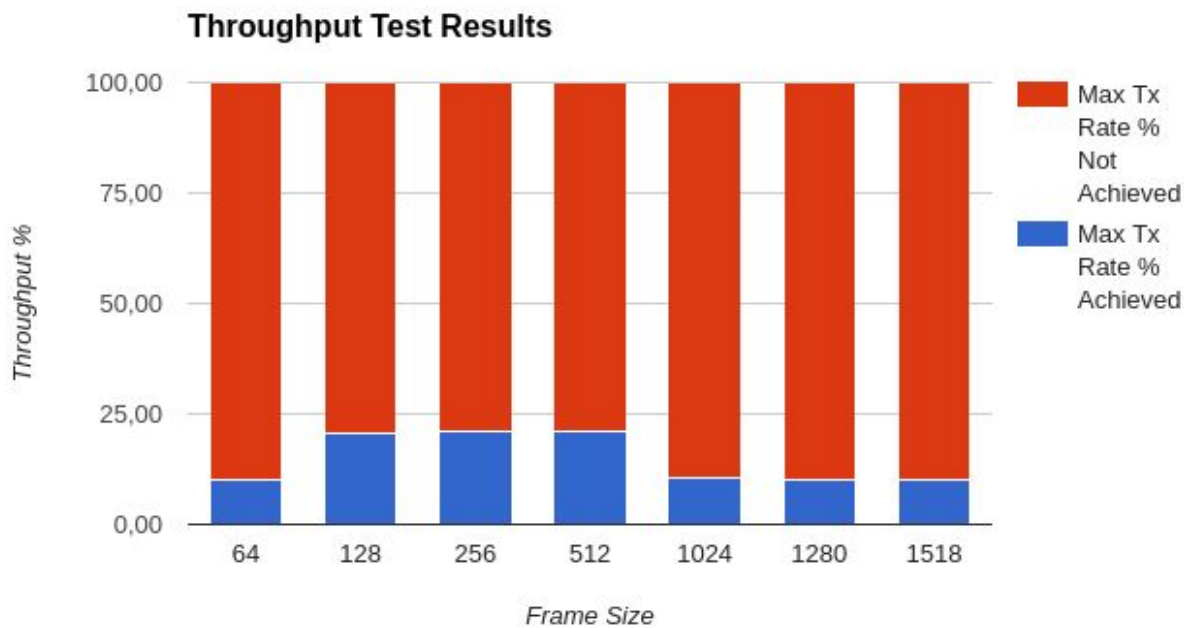

2.2.2 Part Mesh 1: N Results

Forwarding Test Result

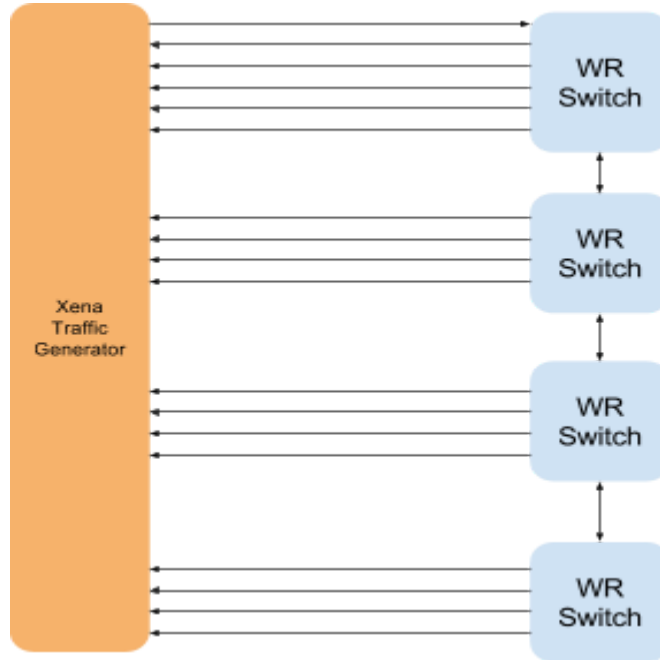

Port 1 Tx and the rest Rx

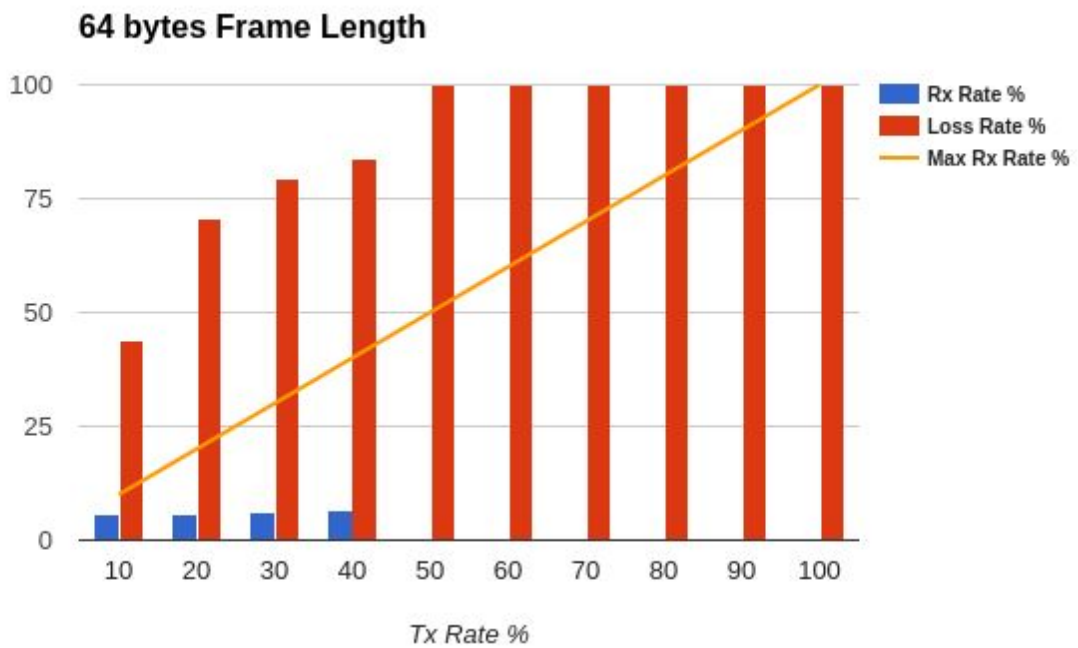

512 bytes Frame Length

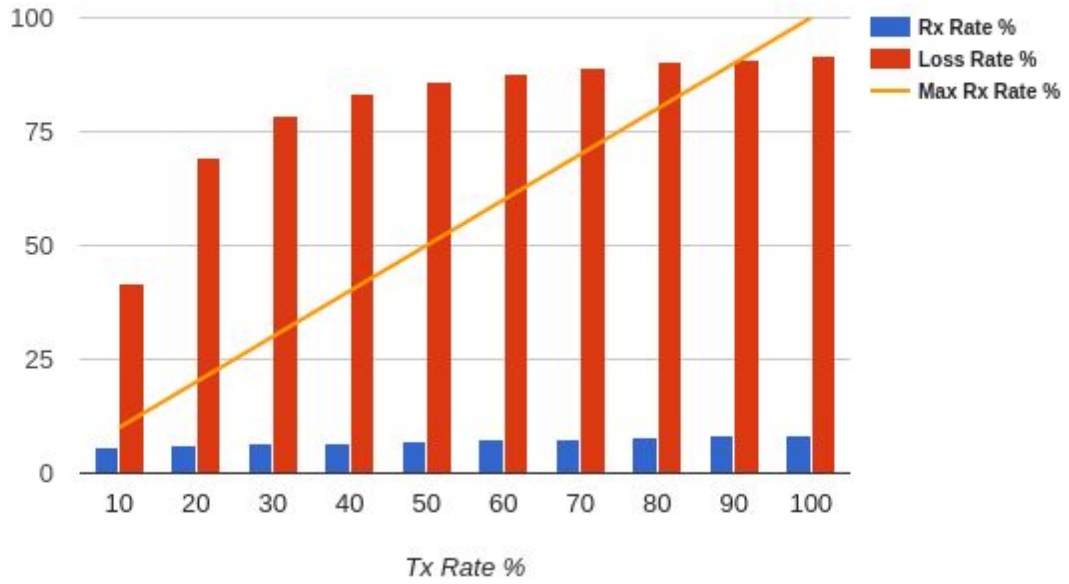

1518 bytes Frame Length

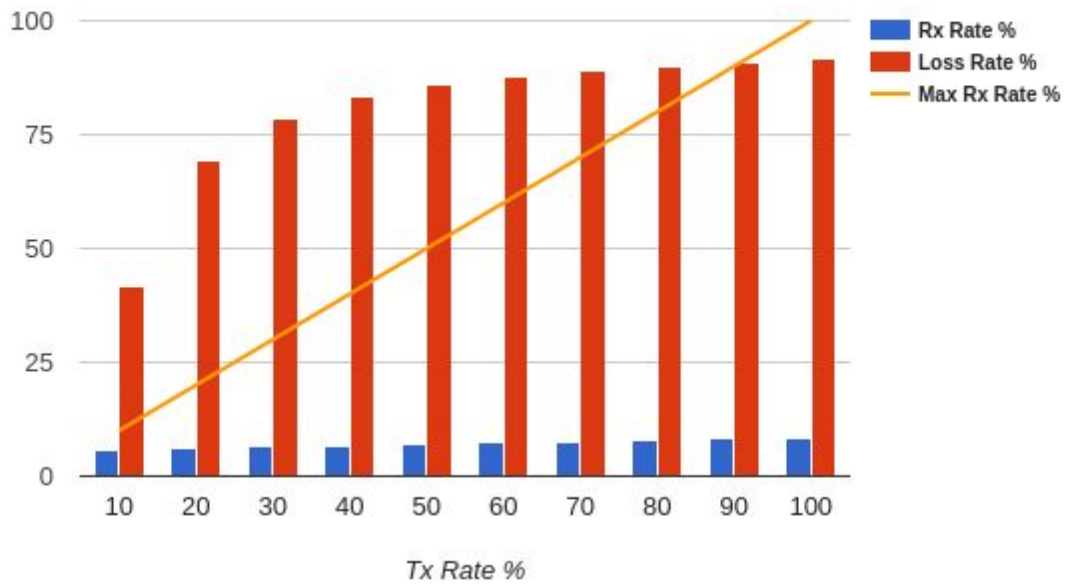

Throughput Test Results

Frame Size	Result State	Max Tx Rate % Achieved	Rx Rate %	Loss Rate %
64	FAIL	10	5,60	43,98
128	FAIL	10	5,71	42,92
256	FAIL	10	5,77	42,25
512	FAIL	10	5,81	41,87
1024	FAIL	10	5,83	41,67
1280	FAIL	10	5,84	41,63
1518	FAIL	10	5,84	41,60

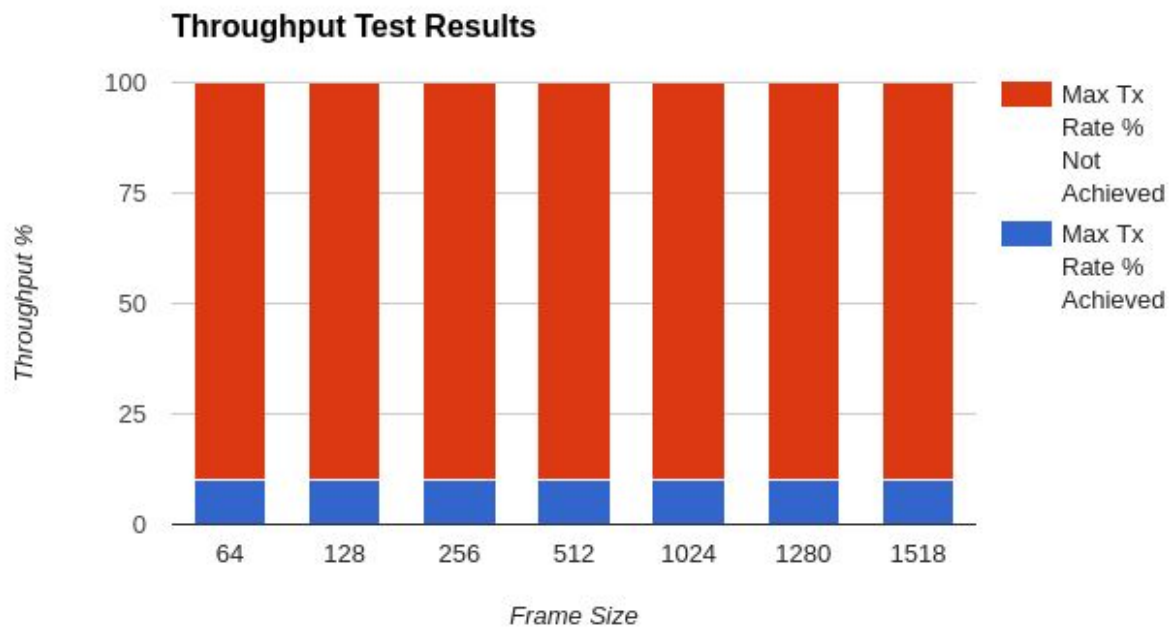

2.2.3 Part Mesh N: N Results

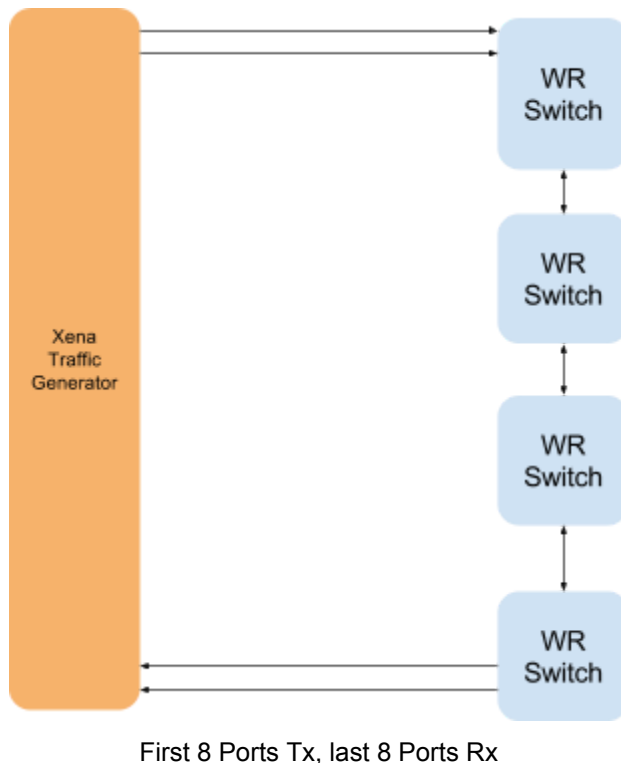

Forwarding Test Results

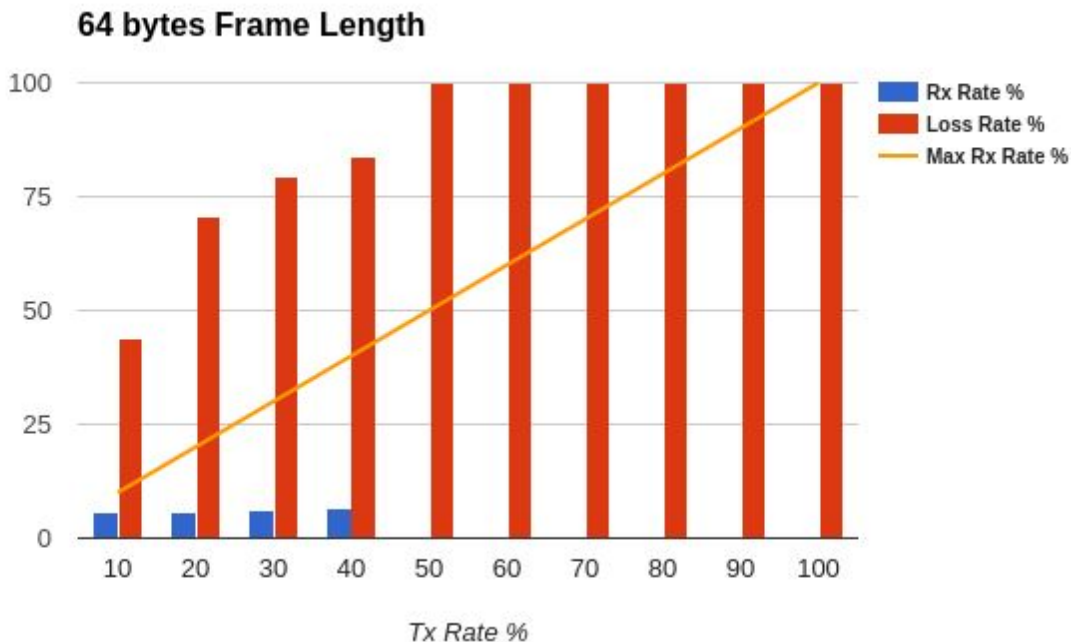

512 bytes Frame Length

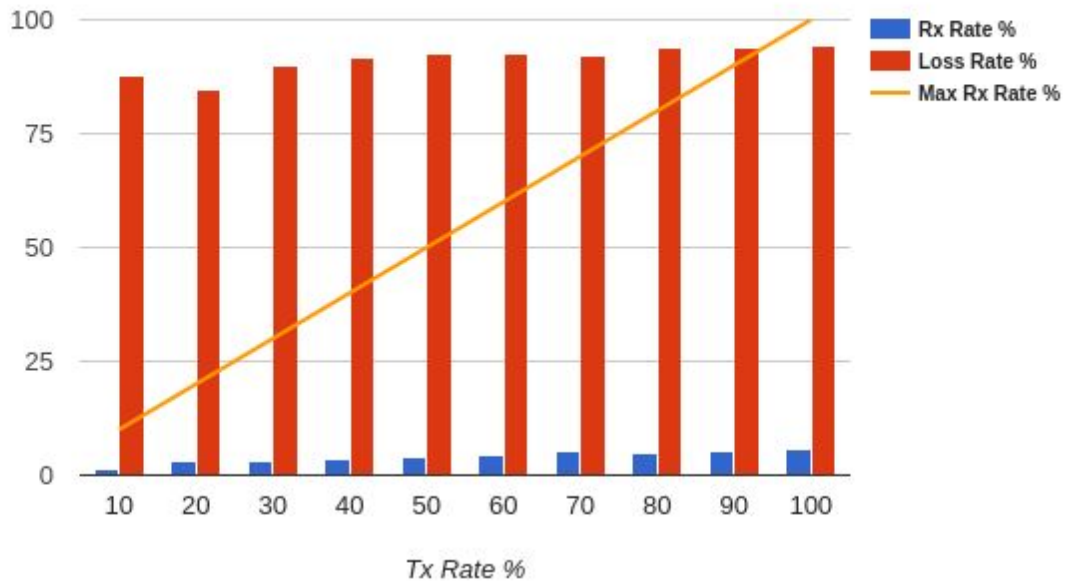

1518 bytes Frame Length

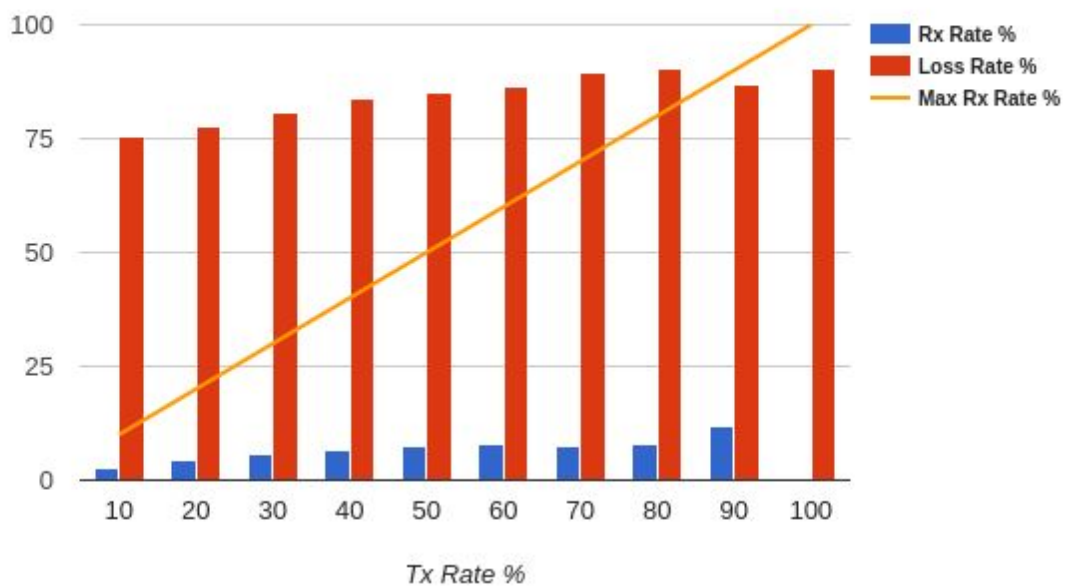

Throughput Test Results

Frame Size	Result State	Max Tx Rate % Achieved	Rx Rate %	Loss Rate %
64	FAIL	10	1,56	84,40
128	FAIL	10	1,67	83,26
256	FAIL	10	1,69	83,13
512	FAIL	10	5,39	46,14
1024	FAIL	10	1,77	82,26
1280	FAIL	10	1,29	87,05
1518	FAIL	10	1,60	84,05

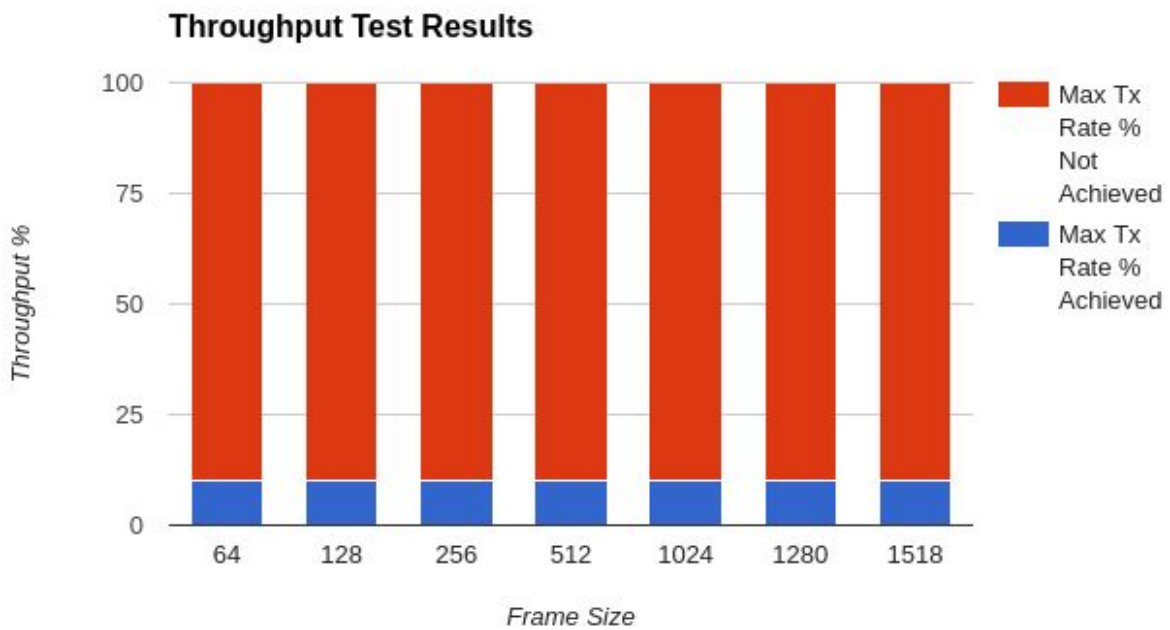

2.2.4 Congestion Control

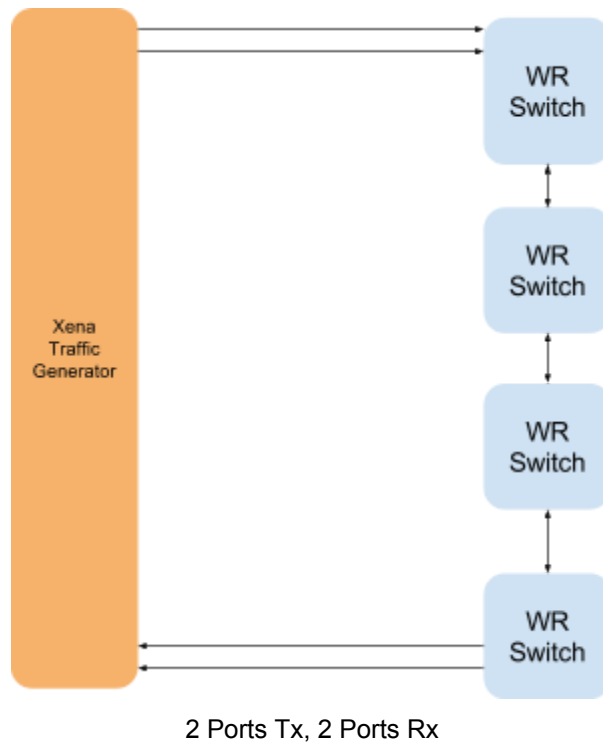

Frame Size	Tx Rate %	Tx	UC-Port:Tx	UC-Port:Rx	UC-Port:Loss %	C-Port:Tx	C-Port:Rx	C-Port:Loss %
64	100	89332017	22331508	13264358	40,60	67000509	29380722	56,15
128	100	50698926	12673890	9343151	26,28	38025036	15344647	59,65
256	100	27200428	6799597	4565265	32,86	20400831	8843695	56,65
512	100	14109365	3527103	341773	90,31	10582262	6655466	37,11
1024	100	7190470	1797500	81345	95,47	5392970	1022916	81,03
1280	100	5773520	1443284	669173	53,64	4330236	1381423	68,10
1518	100	4881111	1220208	345448	71,69	3660903	1975764	46,03

C-Port: Congested Ports

UC-Port: Uncongested Ports

2.2.5 Forward Pressure

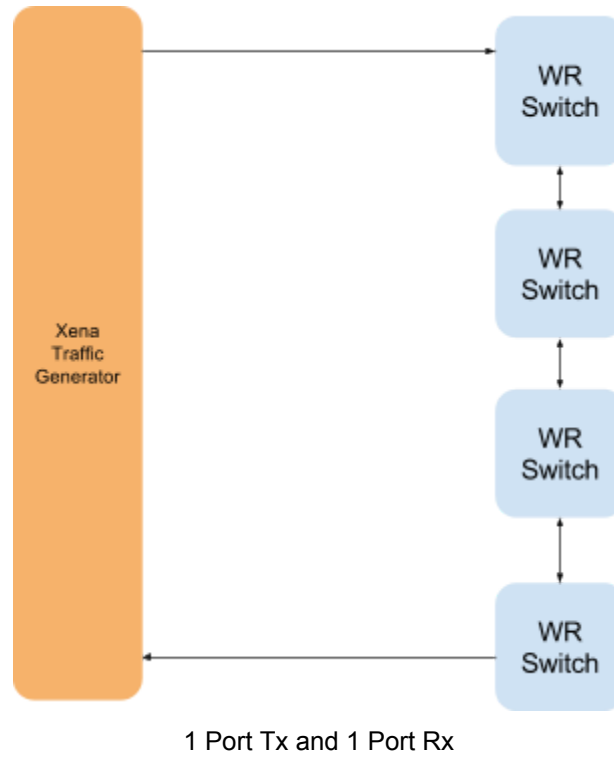

Frame Size	Tx (Frames)	Tx Max. Util. %	Rx (Frames)	Rx Max. Util. %	Loss %
64	45180722	101,2048173	42613342	95,453748	5,682467845
128	25510204	100,6802718	24670862	97,3674832	3,290220651
256	13636363	100,3636317	13392733	98,57011954	1,786620083
512	7062146	100,1883113	6989967	99,1634776	1,022054769
1024	3595397	100,0958525	3527142	98,194464	1,898399537
1280	2886836	100,0769813	2811265	97,45386857	2,617779465
1518	2439817	100,0650279	2376315	97,45791869	2,602736189

2.2.5 Maximum Forwarding Rate

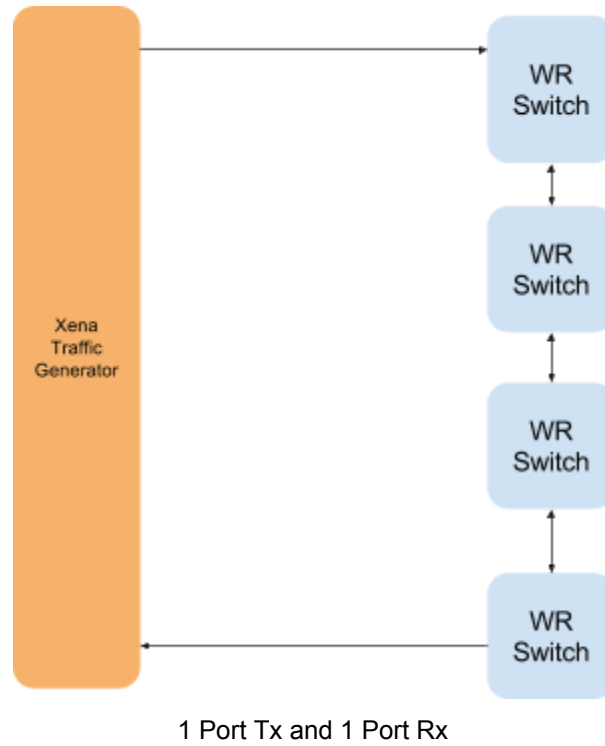

Frame Size	Tx Rate %	Tx (Frames)	Rx (Frames)	Loss %
64	100	44642857	42613355	4,546084495
128	100	25337837	24670858	2,632343874
256	100	13586956	13392732	1,429488695
512	100	7048872	6990064	0,8342895147
1024	100	3591954	3515210	2,136552974
1280	100	2884615	2808591	2,635499018
1518	100	2438231	2376256	2,541801823

2.2.7 Address Caching Capacity and Learning Rate

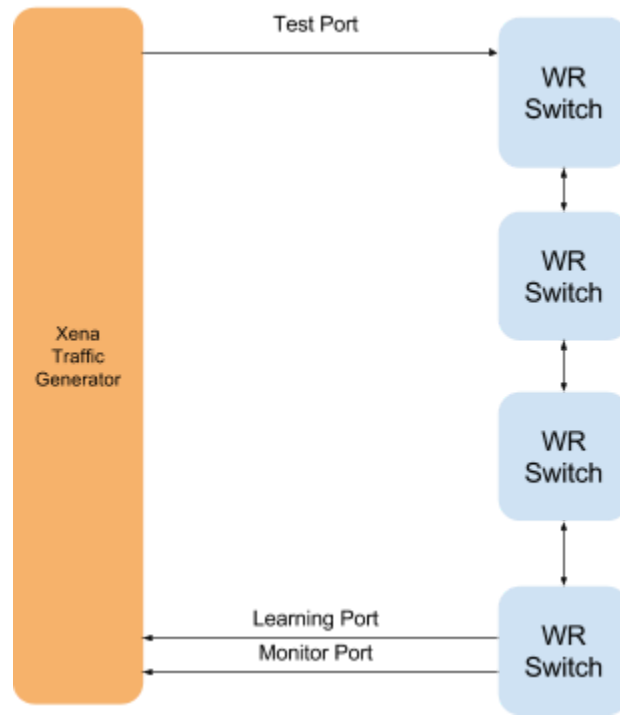

Frame Size	Address Count	TestPort Tx	LearnPort Rx	Learning Rate %	Address Count	TestPort Tx	LearnPort Rx
64	1504	1504	1504	94,375	1504	1504	1504
128	1504	1504	1504	94,375	1504	1504	1504
256	1504	1504	1504	94,375	1504	1504	1504
512	1504	1504	1504	94,375	1504	1504	1504
1024	1504	1504	1504	94,375	1504	1504	1504
1280	1504	1504	1504	94,375	1504	1504	1504
1518	1504	1504	1504	94,375	1504	1504	1504

2.2.8 Errored Frames Filtering

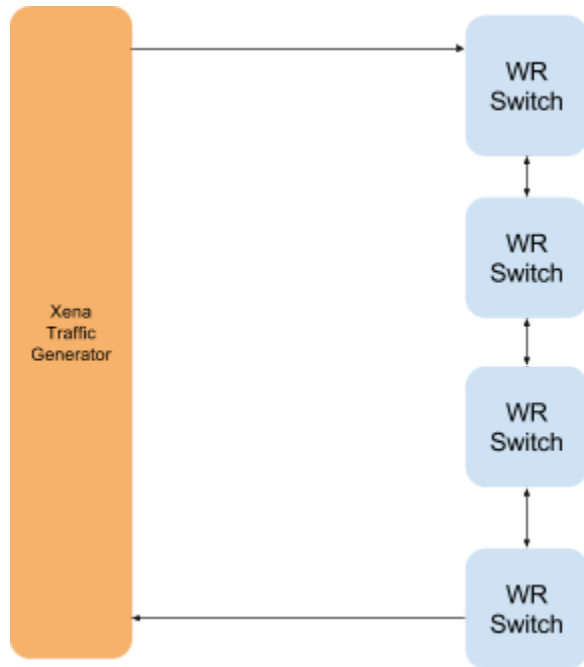

1 Port Tx and 1 Port Rx

Tx Rate %	Result State	Tx	Rx	Tx Valid	Rx Valid	Tx Oversize	Rx Oversize	Tx Undersize	Rx Undersize
10	FAIL	1741375	1741119	154130	154130	81221	81221	1506024	1505768
20	FAIL	3482752	3482287	308261	308261	162443	162443	3012048	3011583
30	FAIL	5224128	5223426	462392	462392	243664	243664	4518072	4517370
40	FAIL	6965499	6964579	616522	616522	324881	324881	6024096	6023176
50	FAIL	8706880	8705808	770653	770653	406107	406107	7530120	7529048
60	FAIL	10448257	10446908	924784	924784	487329	487329	9036144	9034795
70	FAIL	12189633	12188000	1078914	1078914	568551	568551	10542168	10540535
80	FAIL	13931009	13928559	1233045	1233045	649772	649772	12048192	12045742
90	FAIL	15672386	15669755	1387176	1387176	730994	730994	13554216	13551585
100	FAIL	17413762	13695909	1541307	1476538	812215	636881	15060240	11582490

Tx Rate %	Result State	Tx	Rx	Tx Valid	Rx Valid	Tx FCS Error	Rx FCS Error
10	PASS	1741375	1741375	154130	154130	59	0
20	PASS	3482752	3482752	308261	308261	59	0
30	PASS	5224128	5224128	462392	462392	59	0
40	PASS	6965498	6965498	616522	616522	59	0
50	PASS	8706880	8706880	770653	770653	59	0
60	PASS	10448257	10448257	924784	924784	59	0
70	PASS	12189633	12189633	1078914	1078914	59	0
80	PASS	13931009	13930542	1233045	1233045	59	0
90	PASS	15672386	15671881	1387176	1387176	59	0
100	PASS	17413762	13697399	1541307	1476555	59	0

2.2.9 Broadcast Forwarding

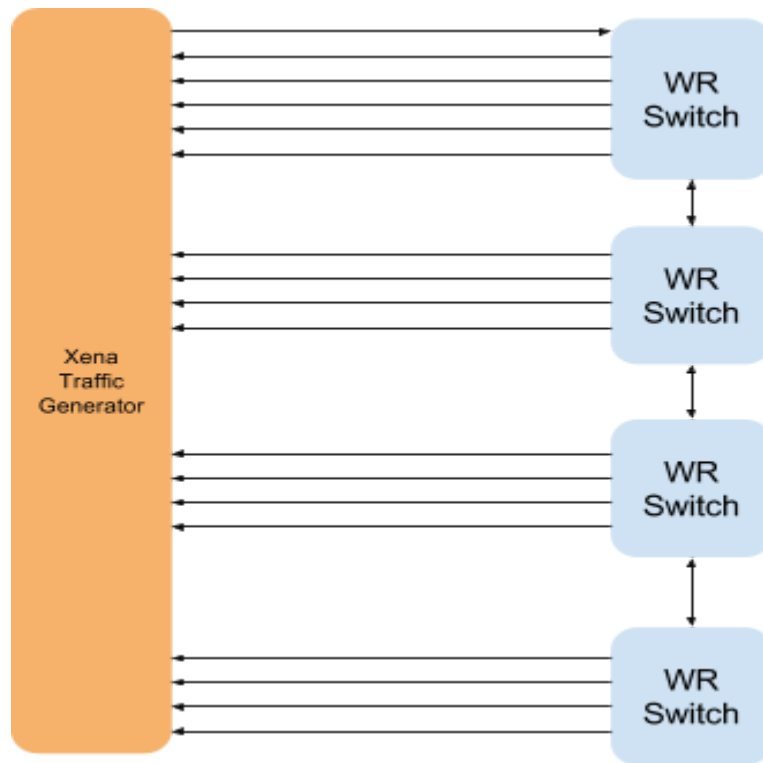

Port 1 Tx and the rest Rx

Frame Size	Tx Rate %	Loss Rate %	Loss (Frames)
64	57,8125	0	0
128	71,875	0	0
256	80,3125	0	0
512	89,453125	0	0
1024	10	0,007123772685	435
1280	10	0,006892561886	338
1518	10	0,007213525916	299

1 Layer

Frame Size	Latency (avg/min/max) (microsecs)	Jitter (avg/min/max) (microsecs)
64	2,358 / 2,190 / 4,620	0,032 / 0,000 / 2,261
128	2,840 / 2,631 / 4,604	0,027 / 0,000 / 1,780
256	2,828 / 2,647 / 4,596	0,011 / 0,000 / 1,780
512	2,850 / 2,655 / 4,724	0,006 / 0,000 / 1,804
1024	2,843 / 2,671 / 4,018	0,001 / 0,000 / 1,250
1280	2,848 / 2,655 / 3,088	0,001 / 0,000 / 0,384
1518	2,852 / 2,663 / 3,409	0,000 / 0,000 / 0,553

2 Layers

Frame Size	Latency (avg/min/max) (microsecs)	Jitter (avg/min/max) (microsecs)
64	4,124 / 3,778 / 6,809	0,030 / 0,000 / 2,501
128	6,293 / 4,676 / 13,071	0,018 / 0,000 / 2,285
256	5,061 / 4,668 / 7,626	0,017 / 0,000 / 2,309
512	5,479 / 4,748 / 10,906	0,009 / 0,000 / 2,453
1024	5,026 / 4,836 / 6,616	0,000 / 0,000 / 1,731
1280	5,031 / 4,844 / 7,514	0,000 / 0,000 / 2,453
1518	5,037 / 4,852 / 6,464	0,000 / 0,000 / 1,491

3 Layers

Frame Size	Latency (avg/min/max) (microsecs)	Jitter (avg/min/max) (microsecs)
64	6,453 / 5,967 / 9,094	0,032 / 0,000 / 2,501
128	9,019 / 7,298 / 15,211	0,026 / 0,000 / 2,285
256	7,783 / 7,266 / 10,513	0,023 / 0,000 / 2,429
512	8,227 / 7,370 / 13,696	0,010 / 0,000 / 2,525
1024	7,763 / 7,458 / 9,310	0,001 / 0,000 / 1,515
1280	7,768 / 7,442 / 10,208	0,001 / 0,000 / 2,453
1518	7,776 / 7,450 / 9,158	0,000 / 0,000 / 1,587

4 Layers

Frame Size	Latency (avg/min/max) (microsecs)	Jitter (avg/min/max) (microsecs)
64	8,861 / 8,308 / 11,700	0,044 / 0,000 / 2,886
128	11,857 / 10,024 / 18,467	0,029 / 0,000 / 2,309
256	10,612 / 9,992 / 13,335	0,021 / 0,000 / 2,333
512	11,058 / 10,120 / 16,518	0,014 / 0,000 / 2,549
1024	10,587 / 10,352 / 12,108	0,001 / 0,000 / 1,419
1280	10,592 / 10,361 / 13,031	0,001 / 0,000 / 2,357
1518	10,596 / 10,272 / 12,076	0,000 / 0,000 / 1,611

3. Result Overview

In order to provide a more comprehensible overview of the results we have summarized the test reports generated by Xena2889. In this overview we don't try to explain, clarify or speculate why the switch has passed or failed a test. If you want to consult and check the original reports from Xena, please check our repository¹⁰.

In this chapter we use a color code to indicate if the WR Switch **passes** or **fails** a test. Also to indicate if the results are **non-conclusive**.

3.1 Result Summary 1 WR Switch

- **Full Mesh and Part Mesh Tests:** According to the results there are frame losses for all lengths used in the test (64, 128 ... 1518) and all possible bandwidths (from 10% to 100%). There are topologies that work better than others (Full Mesh or Part Mesh topologies), and lengths of frames that are massively lost during the forwarding in the switch e.g. 64 and 128 bytes frames. The throughput tests show that it is not possible for the switch to achieve the 100% rate in any topology.
- **Congestion control:** For short frames length, the congestion control seems to work, but for lengths over 256 bytes there is loss of frames.
- **Forward Pressure:** The switch passes the test. It can guarantee 96 bits Interpacket Gap even if the incoming frames have a Interpacket Gap, less than 96 bits.
- **Max Forwarding Rate:** The switch achieves 100% Tx rate with losses of frames.
- **Address Caching Capacity and Learning Rate:** The switch can allocate 1504 MAC addresses with a 94,375 learning rate. We cannot evaluate this result. The WR Switch should be compared with a PTP capable 18 ports switch, in the same price range. We haven't found it.
- **Errored Frames Filtering:** The switch can't filter oversize and undersize frames
- **Errored Frames Filtering:** The switch can filter FCS frames.
- **Broadcast Forwarding:** The switch can almost handle 100% of the broadcast traffic from one-to-many ports at various traffic loads, but for frame lengths under 512 bytes the rate goes down till 60%.
- **Latency:** The value measured fulfills the GSI requirements.

¹⁰ https://github.com/GSI-CS-CO/network_testing.git

3.2 Result Summary 4 WR Switch

- **Full Mesh and Part Mesh Tests:** According to the results there are frame losses for all length used in the test (64, 128 ... 1518) and all possible bandwidths (from 10% to 100%). The throughput tests show that it is not possible for the switch to achieve the 100% rate in any topology.
- **Congestion control:** Not working.
- **Forward Pressure:** The switch passes the test it can guarantee 96 bits Interpacket Gap even if the incoming frames Interpacket Gap is less than 96 bits.
- **Max Forwarding Rate:** The switch achieves 100% Tx rate with loss of frames.
- **Address Caching and Learning Rate:** The switch can allocate 1504 MAC addresses with a 94,375 learning rate. We cannot evaluate this result. The WR Switch should be compared with a PTP capable switch, 18 Ports in the same price range. We haven't found it.
- **Errored Frames Filtering:** The switch can't filter oversize and undersize frames.
- **Errored Frames Filtering:** The switch can filter FCS frames.
- **Broadcast Forwarding and Latency:** The results show a poor performance for length over 512 bytes, and a not outstanding performance in smaller frames: 57% for 64 bytes frames.
- **Latency:** Since this is a use case dependent, for GSI, the latency in average is almost always within the specification.

3.3 Creotech and 7Solutions WR Switches

We have used switches manufactured by Creotech and 7Solutions and we haven't seen or found during the tests any significant difference in the results. The RFC 2889 is a not Hardware test in order to quantify robustness or endurance of the product.

3.4 Follow-Up Work

It would be more than wise to repeat the same RFC with other Traffic Generator in another facility. It could happen that the Xena software or hardware is flawed and the results are wrong or the Timing Group of GSI has made a mistake in the configuration. Another useful test would be to test a off the shelf switch comparable to the WR Switch. Finally, another wise decision would be to carry out the RFC targeting VLANs in the WR Switch.