

Probing the FBAS event signaling via the WR timing network

Enkhbold Ochirsuren

18.1.2023

<https://www-acc.gsi.de/wiki/Timing/Intern/ProbingMPSEventSignalling>

Agenda

- Introduction
- SIS100 MPS class 2 network
- Timing system basics
- Tests & measurements
- Summary

Introduction

- FBAS event signaling
 - via the Timing network
 - according to Technical Concept “Conceptual Design of the SIS100 Fast Beam Abort System (MPS)” (F-TC-C-03e)
- MPS classes regarding reaction time
 - very fast (1) – reaction time at min. 40 us
 - **fast (2)** – reaction time a few ms (for FBAS 1 ms)
 - slow (3) – reaction time within 100 ms

SIS 100 MPS class 2 network

- FBAS events [MPS_FS_040/110/700]
 - CMOS signals from equipments
 - timing events from Data Master
- FBAS logic modules [MPS_FS_1030]
 - DSP MPS card
 - transmitter SCU
 - receiver SCU
 - common node

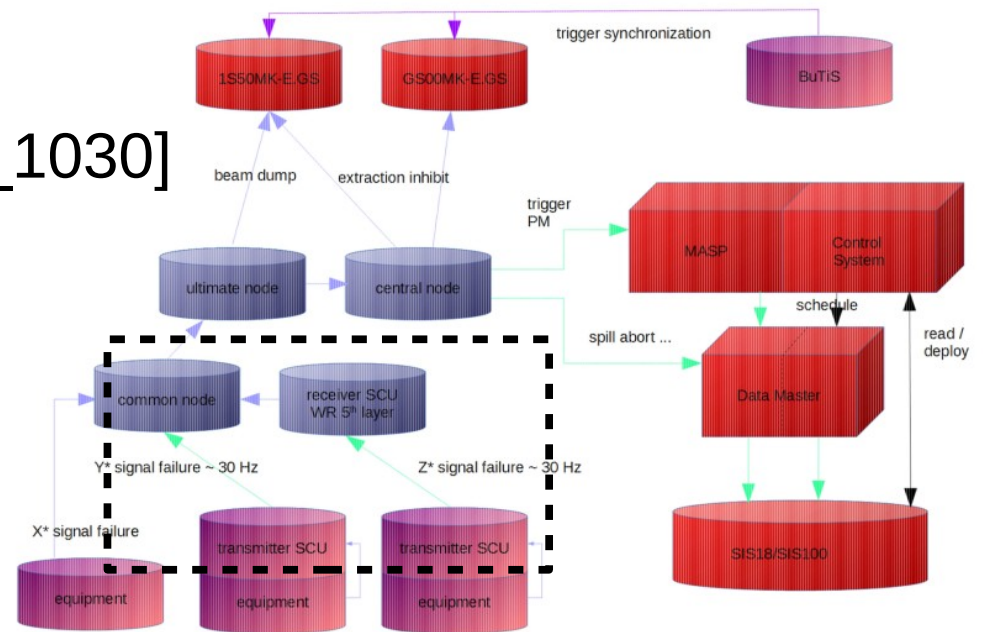

Timing system basics

- General Machine Timing (GMT) system
 - timing event distribution
 - uses White Rabbit (WR), EtherBone (EB)
 - key components
 - WR switch (WRS): for network infrastructure
 - Clock Master (CM): WR switch with time reference (GPS)
 - Data Master (DM): WR node that broadcasts timing messages
 - Timing Receiver (TR): WR node that is capable to execute local action on timing event

Timing system basics

- Timing event
 - Data Master (DM)
 - broadcasts the scheduled commands (timing messages)
 - Timing Receiver (TR)
 - embedded in FEC
 - interprets the incoming events and
 - trigger actions at the designated time
 - inside TR
 - ECA is responsible to execute action on incoming events
 - actions are
 - pulses on LEMO port
 - host interrupts
 - ECA needs to be pre-configured
 - by user-space program in host

- Event: DM telegram
- Condition: index
- Action: configured, executed on-time

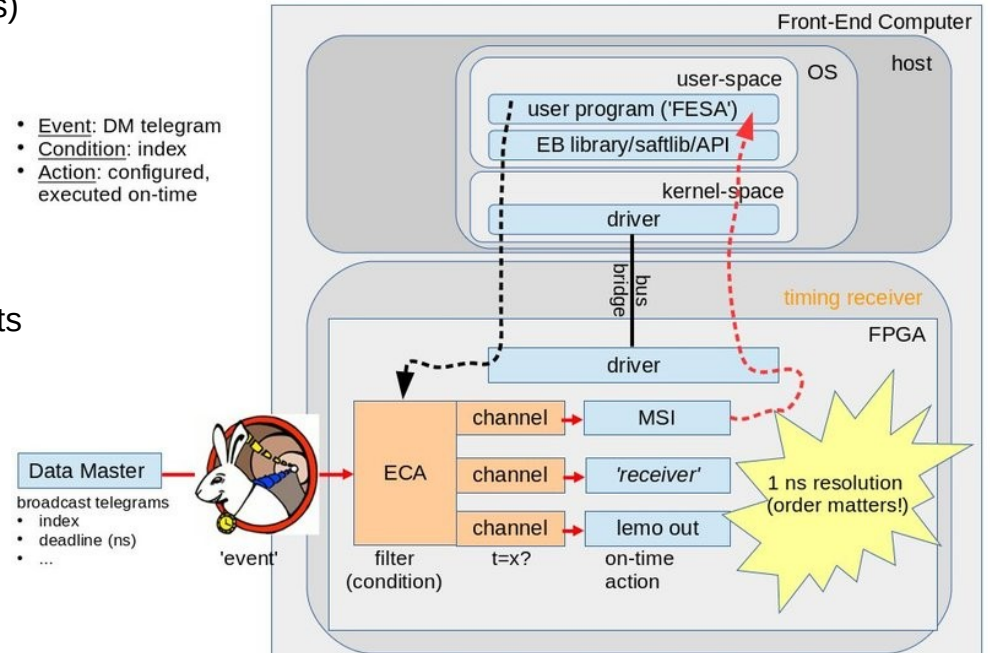

Timing system basics

- WR timing network

- promises

- low latency (100 us/layer)
- packet loss 10^{-12}

- organized in VLANs

- WRSs are aware of VLAN
 - tagging/untagging frames
 - forward/drop frames

- supports

- traffic isolation
- node authentication
- priority is possible

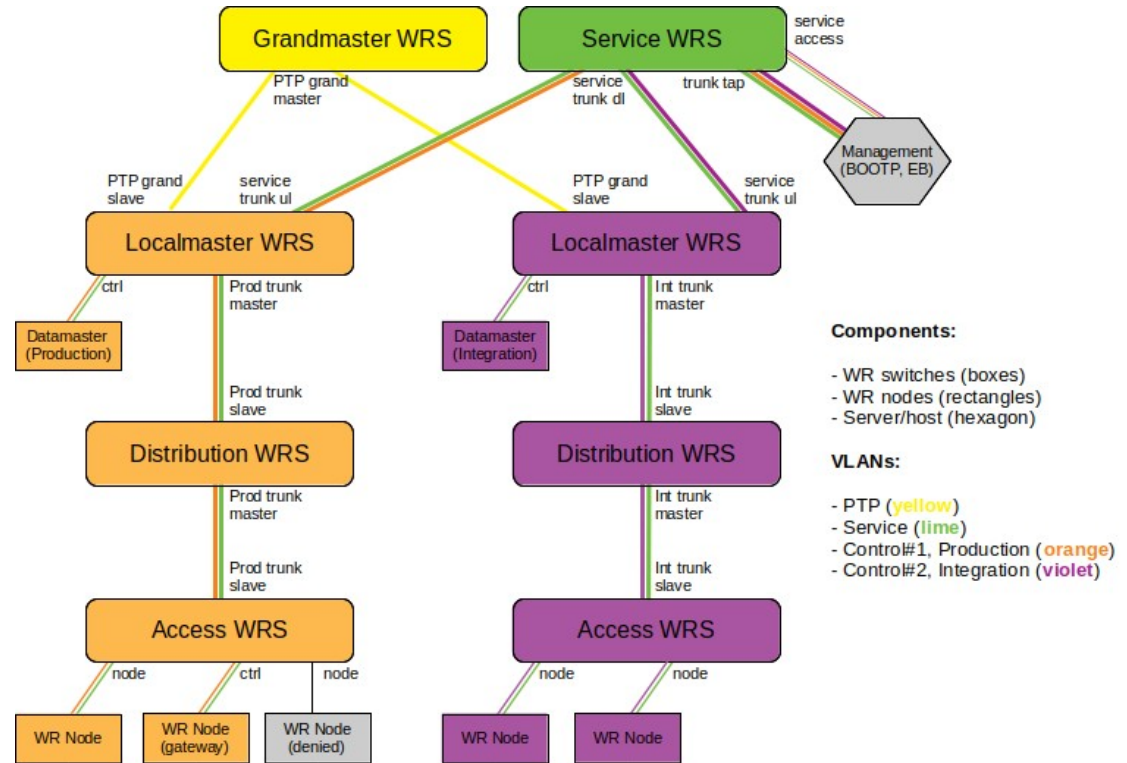

Tests & measurements

- Check timing network performance as initial step
- FBAS requirements [MPS_FS_580]
 - low latency: 1 ms
 - event loss: 10^{-4}
 - data rate of receiver SCU: 300Kb/s

Tests & measurements

- Test components

- SCUs with special LM32 firmware

- transmitter SCU

- convert logic signal to MPS protocol data (MPS_FS_510/520/540/550)
 - send MPS protocol data (MPS_FS_530/560)
 - handle timing messages of DM (MPS_FS_620/700/730/740/750)

- receiver SCU

- handle timing messages of transmitter (MPS_FS_560/590)
 - evaluate MPS protocol data (MPS_FS_640)
 - monitor interval failure (MPS_FS_600)
 - handle timing messages of DM (MPS_FS_630/700/730/750)

- WRSs with special configurations

- Data Master for broadcasting pseudo MPS protocols

- XenaBay for network traffic generation and analysis

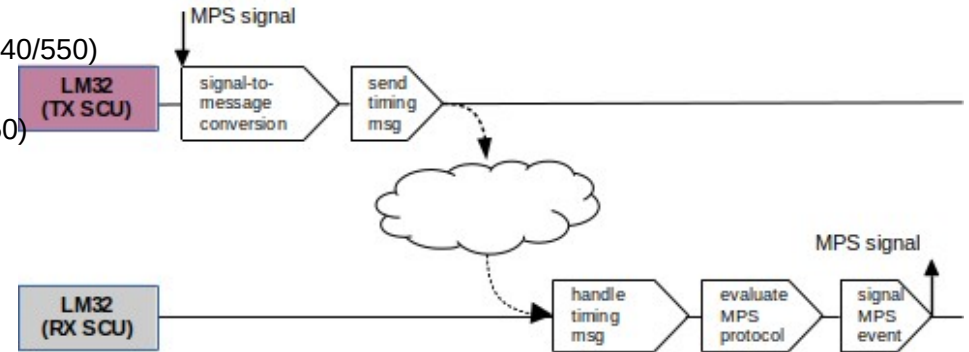

Tests & measurements

- Pseudo MPS protocol [MPS_FS_520]
 - **timing message**, 44 bytes
 - event ID: 0x1fcbfcb0 (group = 0xfcb, event = 0xfcb)
 - parameter
 - MPS flag: 1 byte
 - (suggestion) MPS channel: 1 byte
 - device ID (MAC): 6 bytes
 - timestamp: 8 bytes
 - Ethernet frame, 110 bytes
 - incl. interframe gap of 8 bytes

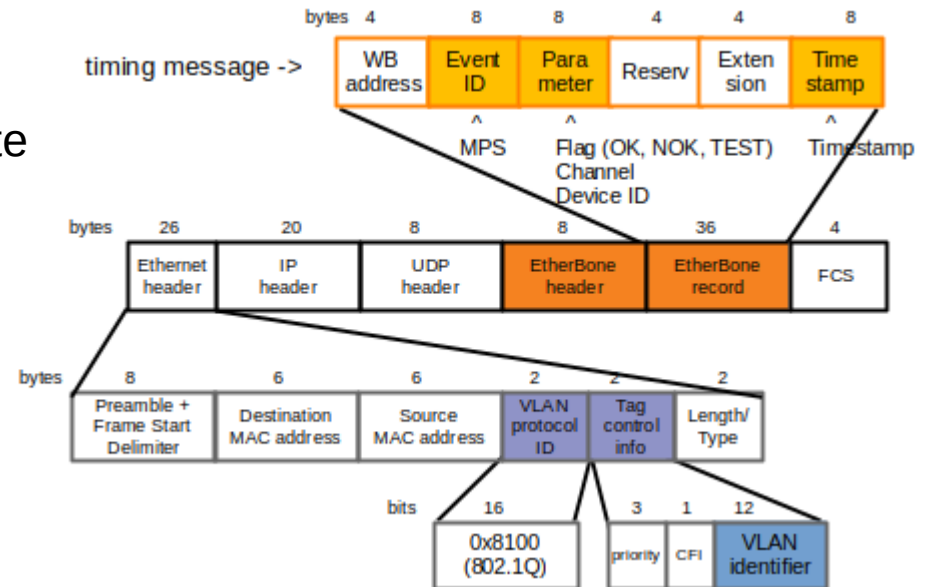

Tests & measurements

- #1: FBAS signaling latency
 - timing delays
 - one-way (timing msg -> ECA)
 - transmission (MPS flag -> ECA)
 - use timestamps (tim. msg vs ECA)

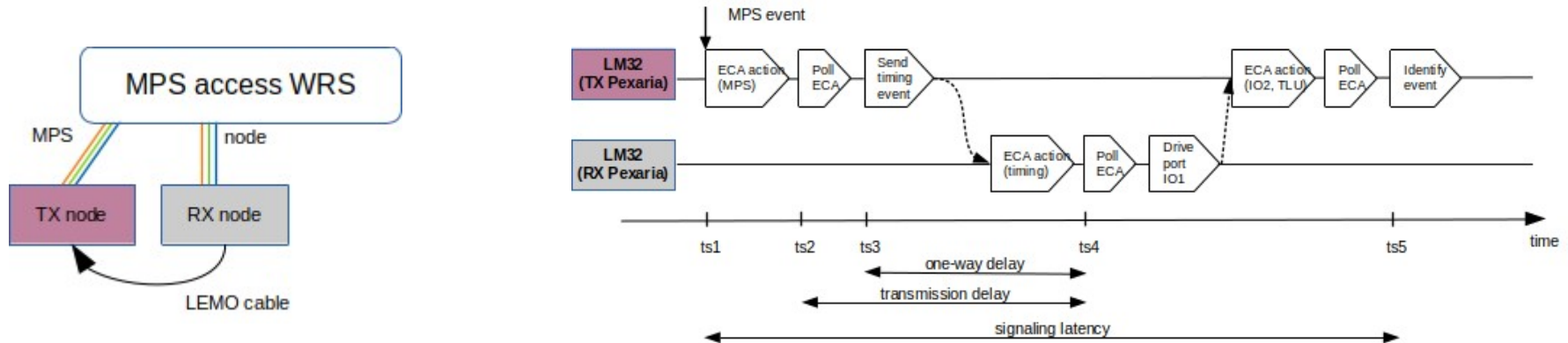

Tests & measurements

- #1: FBAS signaling latency
 - result: avg/max latency 45/**136** us

delay/latency	avg, ns	min, ns	max, ns	RX/TX timing msg
signaling latency	44702	40856	136320	1999/1999
transmission delay	29018	27864	123152	1999/1999
one-way delay	22994	20872	78384	6659/6659

Tests & measurements

- #1: FBAS signaling latency
 - access-layer WRS configuration
 - special configuration: similar for B2B

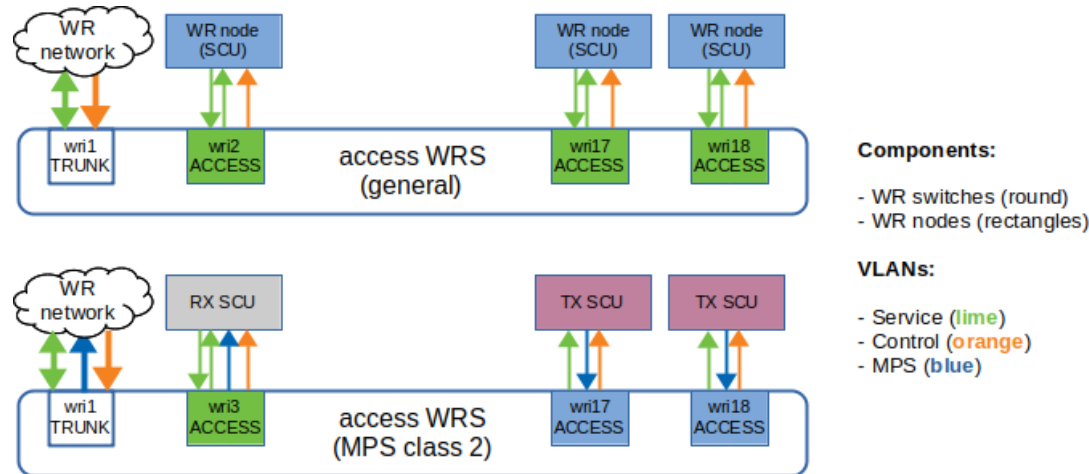

Tests & measurements

- #2: WR network traffic latency, loss
 - 4 physical layers of WRSs
 - 3 VLANs
 - traffic generated by XenaBay:
 - DM (110 byte, VID 7, prio 7)
 - broadcast (100 Mb/s)
 - unicast (10 Mb/s)
 - service (64-1518 byte, VID 5, prio 7, 1/2 Mb/s)
 - MPS (110 byte, VID 6, prio 5)
 - 1x protocol (26,4 Kb/s)
 - 16x protocol (422,4 Kb/s)

Tests & measurements

- #2: WR network traffic latency, loss

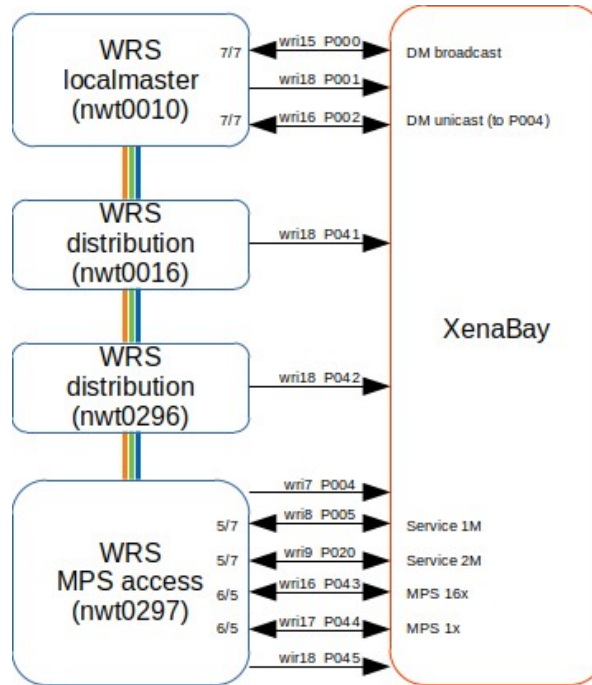

Tests & measurements

- #2: WR network traffic latency, loss
 - result: no traffic loss
 - avg/max latency
 - DM: 11/35 us (broadcast), 11/32 us (unicast)
 - MPS protocol: 14/47 us (16), 11/34 us (1)

layer	avg latency, us	max latency, us	avg jitter, us	max jitter, us	DM traffic
1	3	25/16	0,02/002	22/13	broad/uni
2	5	27/19	0,03/002	22/15	broad/uni
3	8	30/21	0,03/003	22/13	broad/uni
4	11	35/32	0,21/004	24/22	broad/uni

layer	avg latency, us	max latency, us	avg jitter, us	max jitter, us	MPS protocol
1	5/3	37/25	0	34/22	16/1
2	8/5	40/28	0	35/23	16/1
3	11/8	43/30	0	35/23	16/1
4	14/11	47/34	0	35/23	16/1

Tests & measurements

- #3: message loss
 - simultaneous traffic (XenaBay)
 - message rates: 30-5000 Hz (24-4000 Kb/s)
 - injected into remaining 15 ports of WRS
 - lost: messages received later than 1 ms or dropped

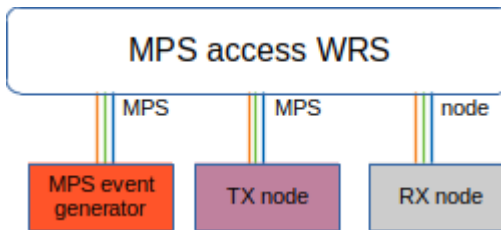

Tests & measurements

- #3: Message loss

- result: message loss at 2500 Hz with additional 15 transmitters

msg rate, Hz (data rate, Kb/s)	avg one-way delay, us	min one-way delay, us	max one-way delay, us	RX/TX timing msg	message loss of TR
30 (24)	76,31	20,46	139,24	32207/32207	no
120 (96)	76,40	20,47	145,66	122493/122493	no
400 (300)	76,38	20,45	150,33	378385/378385	no
800 (600)	77,04	20,44	159,94	754186/754186	no
1250 (1000)	81,36	20,64	173,21	1255368/1255368	no
2500 (2000)	92,10	20,58	1271,94	2509332/2509332	yes
5000 (4000)	3570,69	20,53	4568,64	3439252/5017884	yes, dropped

Tests & measurements

- #4: data rate of receiver
 - criteria: overflow of ECA queue
 - message rates: 300 Hz - 100 KHz
 - 1/3/16 MPS protocols per timing message
 - 6K MPS protocols sent by DM

Tests & measurements

- #4: data rate of receiver

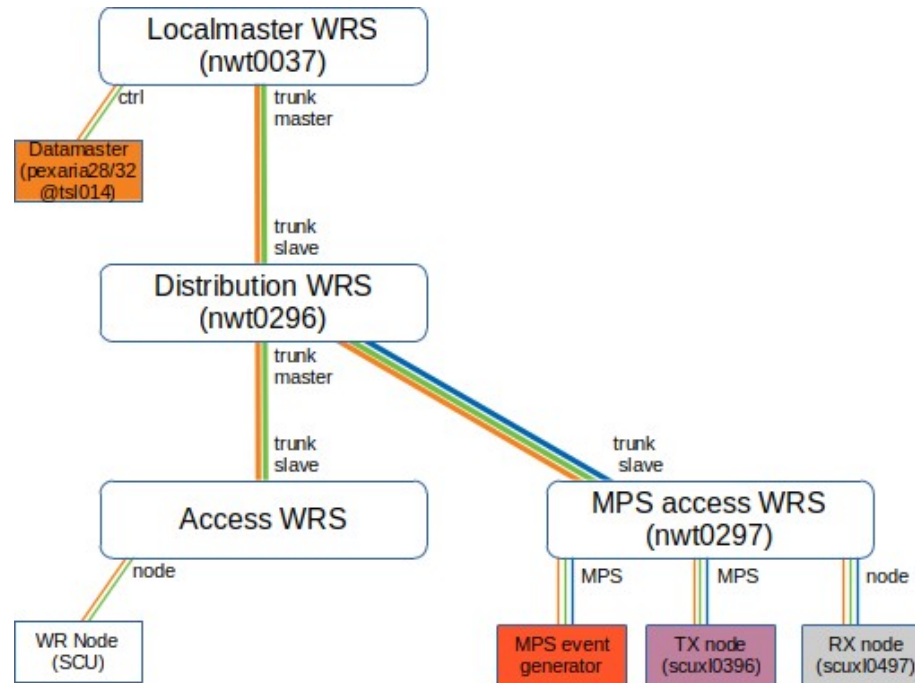

Tests & measurements

- #4: data rate of receiver
 - result
 - LM32 firmware (TR): 20 KHz (17,6 Mb/s)
 - complete SW stack (TR+host): 1 KHz (880 Kb/s)

Summary

- verified network performance considering MPS_FS_580
 - signaling latency (1 ms)
 - max. 136 us (avg. 45 us) MPS signaling latency, 1x message, 1 physical layer of WRS (test #1)
 - max. one-way delay 78 us (tim. msg -> ECA)
 - max. 25 us (avg. 3 us) network latency, 1x message, 1 physical layer (test #2)
 - around 3 us for each layer
 - max. 34 us (avg. 11 us), 4 physical layers
 - message loss (10^{-4}) and receiver data rate (300 Kb/s, corresponds to 11 messages)
 - no network packet loss (test #2)
 - max. message rate of TR
 - max. 1250 Hz: 16 senders, 1 message, 1 physical layer (test #3)
 - max. 20 KHz: 1 sender, up to 16 MPS protocols, 3 physical layers (test #4)
- tiny testbed
 - covers timing system parts (not SCU/host)

Summary

- Determine next steps
- Uncertainties in Technical Concept
 - transmitter/receiver/common SCUs
 - shared, stand-alone
 - MPS event generation [MPS_FS_490]
 - DSP MPS card
 - other
 - MPS protocol data [MPS_FS_520/590]
 - format: VLAN ID, sender's MAC, channel
 - building a common channel [MPS_FS_640]
 - effective logic output
 - configuration [MPS_FS_700/710/720/1890]
 - format of MPS signal masks, parameters
 - operation modes/states (test, normal, configuration)
 - service VLAN is shared for service and control traffic
 - other